

Motorola  
8000 West Sunrise Boulevard  
Fort Lauderdale, Florida 33322

Digital XTS 3000™  
Full-Featured Model

User's Guide

This manual describes how to operate an ASTRO Digital XTS 3000 Full-Featured Model Portable Radio.

The full-featured model has a display, a 3 x 2 control keypad, and a 3 x 4 alphanumeric keypad.

This manual first introduces you to your new radio. Then it covers general radio operation and commonly used radio features. Next, special radio features available on an ASTRO Digital XTS 3000 radio are described. The back section of this manual includes a glossary, alert tone and status indicator tables, helpful tips, and an index.

Use this manual to become familiar with your ASTRO radio. But, before operating your radio, please read and understand the “FCC Safety Standards” on the inside back cover of this manual.

### Notations Used in This Manual

Throughout the text in this publication, you will notice the use of WARNINGS, CAUTIONS, and Notes. These notations are used to emphasize that safety hazards exist, and care must be taken or observed.



**WARNING:** An operational procedure, practice, or condition, etc., which may result in injury or death if not carefully observed.

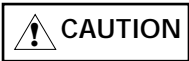

**CAUTION:** An operational procedure, practice, or condition, etc., which may result in damage to the equipment if not carefully observed.

**Notes**

**Note:** An operational procedure, practice, or condition, etc., which is essential to emphasize.

You will also notice the following special notations used to identify certain items:

Example

Description

**Light Button** or

Buttons and keys will be shown in bold print or as a key symbol.

**“FIRE DISP NW”**

Information appearing on the radio’s display will be shown within quotation marks.

**PHON**

Softkeys will be shown as they would appear on the radio’s display.

**OR**

Signifies different steps with the same end result.

Signifies alternating radio display information.

Signifies different steps with a different end results.



# Digital XTS 3000 Full-Featured Model Portable Radio

## Quick-Reference Card

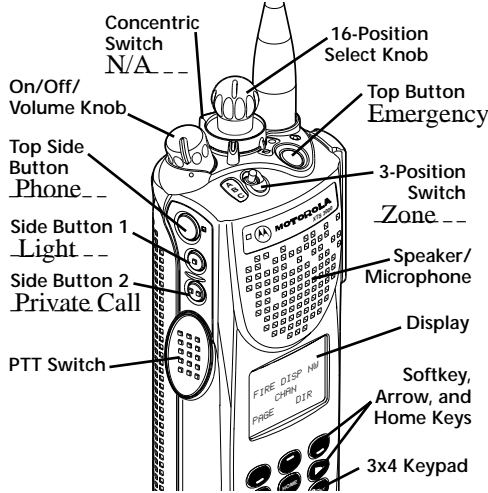

Write your radio's programmed features on the dotted line.

## GENERAL

**Turning the Radio On:** Rotate the **On/Off/Volume Control Knob** clockwise.

**Monitoring (Conventional Channels Only):** Momentarily press the **Monitor Button** and listen for voice activity.

**Transmitting:** Press and hold the **PTT Switch**.

**Receiving:** Release the **PTT Switch**.

## Selecting a Zone and Channel:

1. Press until the **ZONE** softkey appears.
  2. Press directly below **ZONE**.
  - 3a. Press until the desired zone name appears.
- OR -----
- 3b. Enter the number of the desired zone.

*If the displayed zone/channel combination is acceptable:*

4. Press or the **PTT Switch**.

*If you would like a different channel:*

- 4a. Press until the **CHAN** softkey appears.
  5. Press directly below **CHAN**.
  - 6a. Press until the desired channel name appears.
- OR -----
- 4b. Rotate the **Zone/Channel Select Knob** to the desired channel; then go to step 7.
  - 6b. Enter the number of the desired channel.

7. Press or the **PTT Switch**.

## COMMON RADIO FEATURE

### Making an Individual Call:

- 1a. Press until one of the following softkeys appears:
  - 1b. Press the **Phone, Call, or Page Button**; then go to step 3.
- OR

PHON for Telephone Call





CALL for a Private-Conversation Call

PAGE for a Call-Alert Page

2. Press directly below the desired softkey.
- 3a. If you wish to call the last number dialed, press the **PTT Switch**.
- 3b. Press or until you locate the member's number you wish to call.
- 3c. Enter the number that corresponds to that member's placement within the list and press the **PTT Switch**.
- 3d. Enter a new number and press the **PTT Switch**.

## COMMON and SPECIAL RADIO FEATURES

Most of your radio features can be accessed by performing the following steps (for more detail, refer to the feature description in your manual).

- 1a. Press  until the desired softkey appears (see softkey list below).
  - 1b. Press (or rotate) the **Feature Button/Switch** (if programmed, see front of card); this takes you directly to step 3.
- OR
2. Press  directly below the desired softkey.
3. In most cases, the display will change to show the current state of the feature and the available softkey choices.
- 4a. If you want to change the feature state, press  directly below the desired softkey choice.
- OR -----
- 4b. If you **do not** want to change the feature state, press  or the **PTT Switch**.

## Softkey Feature List

Softkey	Feature
CALL	Individual Private-Conversation Call or Selection Call
CHAN	Channel Selection
DIR	Bypass Repeater (Talkaround) and Talk Directly to Another Radio
ERAS	Erasure (Zeroization) of Encryption Key(s)
LOGF	Radio Lock (Log Off)
INDX	Encryption Key(s) Index Grouping
MSG	Message-List Selection
MUTE	Keypad Tones Muting
PAGE	Call-Alert Page
PHON	Telephone Call

Softkey	Feature
PROG	List Programming of Individual-Call Numbers and Scan Channels
PSWD	Program New Password
PWR	TX Power-Level Selection
RPGM	New Dynamic-Regrouping Request
SCAN	Scan Operation
SITE	Multiple Site Selection
STS	Status-List Selection
VIEW	List Viewing
ZONE	Zone Selection

# ASTRO Digital XTS 3000

Portable Radio  
Full-Featured Model

<b>Introduction</b> .....	<b>1</b>
Inspection .....	1
Radio Controls .....	2
Antenna Installation and Removal .....	5
Battery Installation and Removal .....	7
Belt-Clip Installation and Removal .....	8
Universal Connector Cover Installation and Removal .....	9
 <b>General Radio Operation</b> .....	 <b>11</b>
Turning the Radio On and Off .....	11
Selecting a Zone and Channel .....	12
Receiving/Transmitting .....	16
Using Lists .....	17
General Radio Features .....	25
 <b>Common Radio Features</b> .....	 <b>31</b>
Data Calls (Status Calls or Message Calls) .....	31
Emergency .....	33
Individual Calls .....	36
PL Defeat .....	43
Repeater Access .....	43
Repeater/Direct .....	44
Scan .....	45
Selecting Squelch Operation .....	51
Smart PTT .....	52

Motorola, XTS 3000, Private-Line, Digital Private-Line, Call Alert, MDC-1200, DVP, DVP-XL, Private Conversation, Call Alert, SmartZone, and Quik-Call are trademarks of Motorola, Inc.

© 1996 by Motorola, Inc. Radio Products Group  
8000 W. Sunrise Blvd., Ft. Lauderdale, FL 33322  
Printed in U.S.A. 6/96. All Rights Reserved.

**User's Guide**  
**68P81083C75-0**

<b>Special Radio Features</b> .....	<b>53</b>
Dynamic Regrouping .....	53
PTT-ID Receive .....	56
PTT-ID Transmit .....	56
Secure Operation .....	57
Selectable Power-Level .....	62
Trunking System Controls .....	63
<b>Additional Information</b> .....	<b>67</b>
Glossary .....	67
Alert Tones .....	69
Status Indicators .....	71
Battery Charging and Disposal .....	72
Helpful Tips .....	74
Radio Care .....	75
Air Bag Safety Information .....	76
Service .....	76
<b>Index</b> .....	<b>77</b>

For information regarding Factory Mutual Approved models, options, and accessories, refer to the Factory Mutual Approved Supplement for ASTRO Digital XTS 3000 Radios (Motorola part number 68P81084C86).

## Computer Software Copyrights

The Motorola equipment described in this manual may include copyrighted Motorola computer programs stored in semiconductor memories or other media. Laws in the United States and in other countries preserve for Motorola certain exclusive rights for copyrighted computer programs, including the exclusive right to copy or reproduce in any form the copyrighted computer program. Accordingly, any copyrighted Motorola computer programs contained in Motorola equipment described in this manual may not be copied or reproduced in any manner without the express written permission of Motorola. Furthermore, the purchase of Motorola equipment shall not be deemed to grant either directly or by implication, estoppel, or otherwise, any license under the copyrights, patents or patent applications of Motorola, except for the normal nonexclusive, royalty free license to use that arises by operation of law in the sales of a product.

# Introduction

Congratulations on your purchase of Motorola's leading edge in two-way radio communications; ASTRO, the digital solution.

ASTRO digital technology represents a revolution in two-way radio communication. With its expanded benefits and increased flexibility, an ASTRO digital system gives you an advanced new perspective on the way you communicate.

Motorola is committed to leadership in two-way radio communications for all types of private and public use. In addition to providing you with a wide range of analog solutions, Motorola is the leader in developing new digital solutions to serve you today and in the years ahead. ASTRO narrowband technology is the world's first digital two-way radio system. It offers many highly-sophisticated features previously unavailable for users of privately-owned systems, while maintaining compatibility with existing analog systems. Your ASTRO Digital XTS 3000 radio will provide you with many years of dependable service, with the quality and reliability that you expect from Motorola.

## Inspection

Inspect the shipping carton for any signs of damage. Remove and check the contents to be sure that all ordered items have been shipped. Inspect all items thoroughly. If any items have been damaged during transit, report the damage to the shipping company immediately.

## Radio Controls

### Programmable Switches and Buttons

Refer to Table 1 for the features that are programmable through radio service software (RSS) to the ASTRO Digital XTS 3000 radio controls. Then write, in the space provided below the appropriate switch or button on this page, the features that apply to **your** radio's programming (consult your service technician).

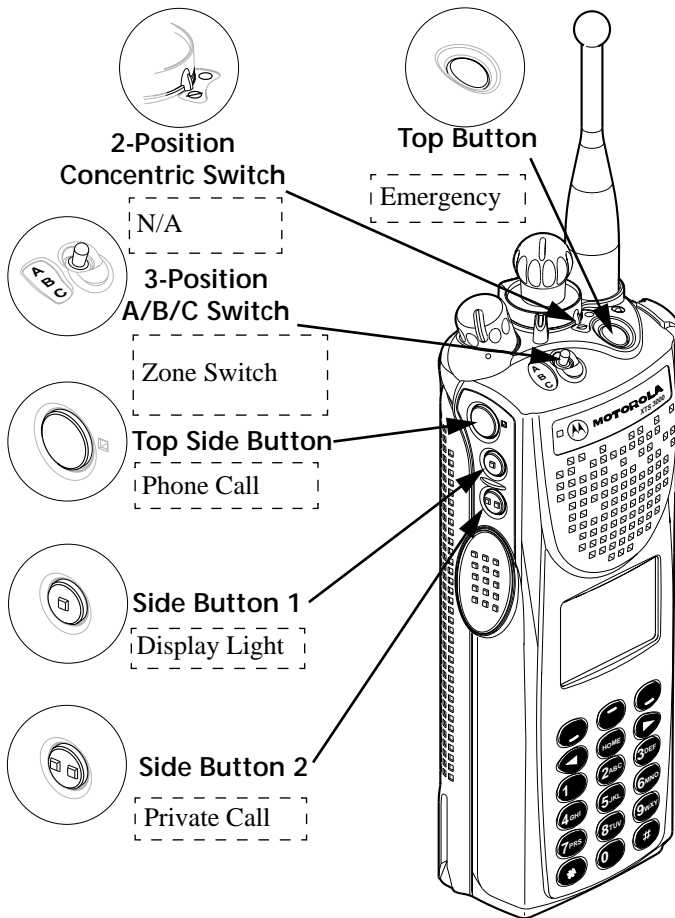

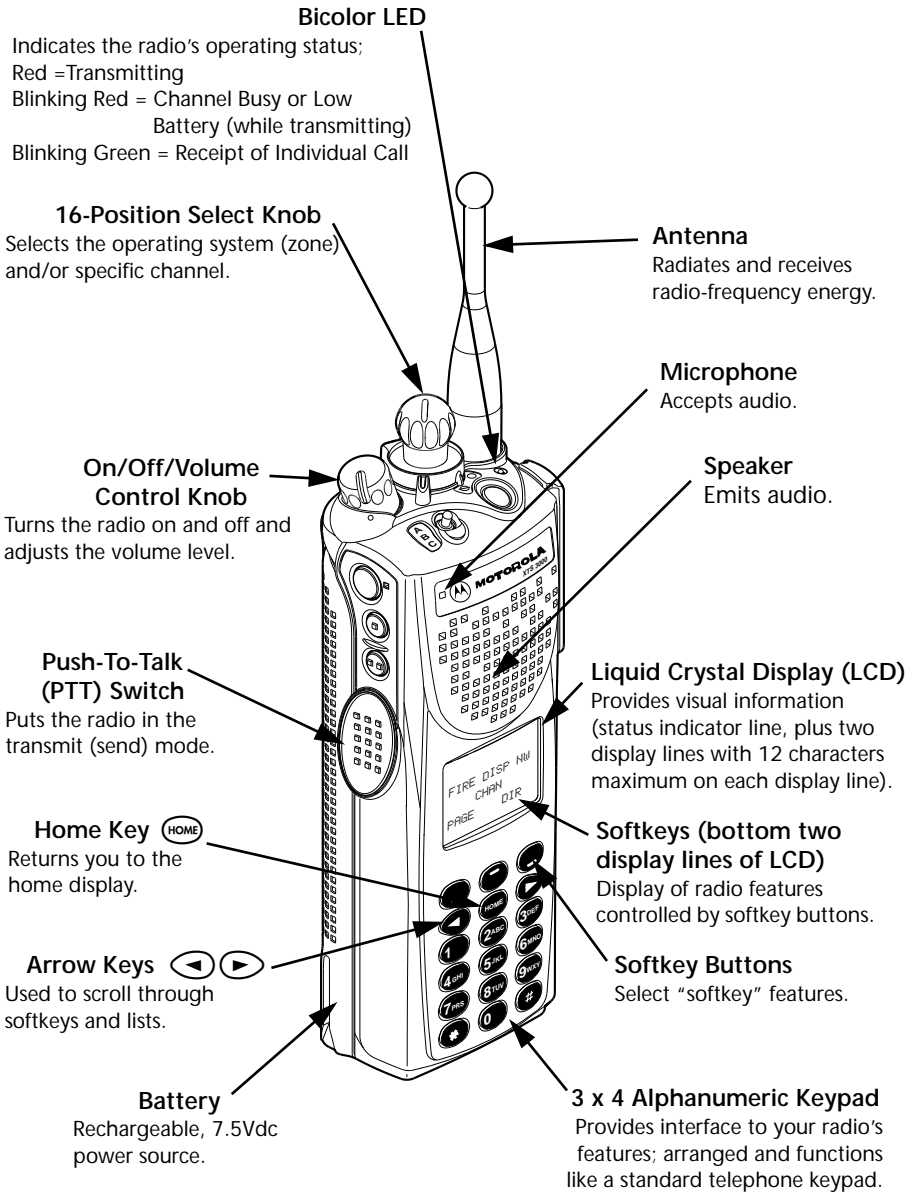

Table 1. Programmable Features

Call Alert™ (pg. 36-43)	Nuisance-Delete (pg. 47)	Secure/Clear (pg. 57 )
Call Response (pg. 42)	Phone (pg. 36-43)	Selective Call (pg. 36-43)
Channel (pg. 12-15)	PL Defeat (pg. 43)	Site Lock/Unlock (pg. 64)
Dynamic Priority (pg. 47)	Private Call (pg. 36-43)	Site Search (pg. 65)
Emergency (pg. 33-35)	Repeater Access (pg. 43)	Status (pg. 31)
Keypad Mute (pg. 29)	Repeater/Direct (pg. 44)	Tx Power-Level (pg. 62)
Light (pg. 74)	Reprogram Request (pg. 54)	Volume Set (pg. 16)
Message (pg. 29)	Scan On/Off (pg. 45-46)	Zone (pg. 12-13)
Monitor (pg. 16)		

(pg.XX) = Page Number of Feature Description

## Switches, Buttons, Knobs, and Indicators



## Antenna Installation and Removal

Before installing the antenna, ensure that the match between your radio and antenna is correct. Your radio's model number is on a label attached to the back of your radio. A typical model number might be H09UCC9PW5AN. The fourth position of the model number (in this example "U") identifies the operating-frequency band of the radio. The following table lists all fourth-position alpha characters and corresponding frequency band.

**Radio Operating-Frequency Table**

Fourth-Position	Operating-Frequency	Fourth-Position	Operating-Frequency	Fourth-Position	Operating-Frequency	Fourth-Position	Operating-Frequency
<b>K</b>	136-178MHz	<b>R</b>	403-470MHz	<b>S</b>	450-512MHz	<b>U</b>	806-870MHz

Antennas are frequency sensitive and are color coded according to the frequency range of the antenna. The color code indicator is in the center of the base of the antenna. The following illustrations and table will help identify the antenna, antenna frequency range, and corresponding color code.

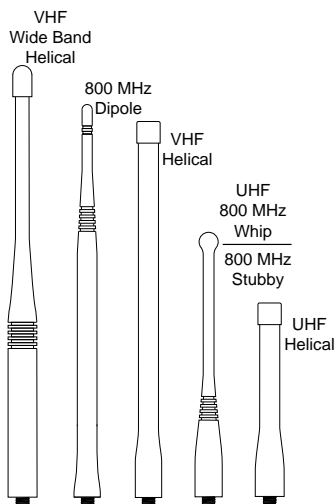

Antenna Identification Table					
Antenna Type	Approx. Length		Insulator Color Code	Frequency Range	Antenna Kit No.
	in.	mm			
VHF Wide Band Helical	8.1	203	RED	136-174MHz	NAD6563
VHF Helical	7.8	195	YELLOW	136-151MHz	NAD6566
	7.3	183	BLACK	151-162MHz	NAD6567
	6.9	172	BLUE	162-174MHz	NAD6568
UHF Helical	3.3	83	RED	403-435 MHz	NAE6546
	3.2	80	GREEN	435-470MHz	NAE6547
	3.2	79	BLACK	470-512MHz	NAE6548
UHF Wide Band Whip	5.2	130	GREY	403-512MHz	NAE6549
800MHz Whip	7	175	RED	806-870MHz	NAF5037
800MHz Dipole	8	200	RED	806-870MHz	NAF5039
800MHz Stubby, Quarterwave	3.3	83	WHITE	806-870MHz	NAF5042

To install the antenna, screw the threaded end of the antenna into the antenna receptacle on the top of the radio. Rotate the antenna clockwise until it seats firmly against the bushing.

To remove the antenna, rotate the antenna counterclockwise until its threaded end unscrews from the radio's antenna receptacle.

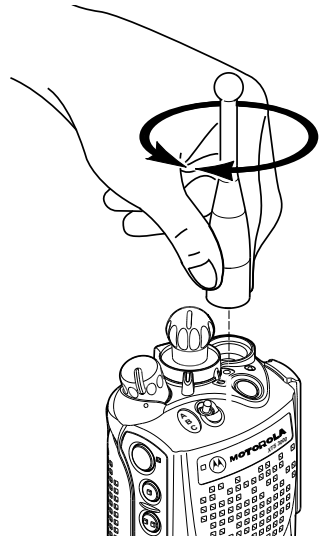

## Battery Installation and Removal



### WARNING

To avoid a possible explosion:  
**DO NOT** replace the battery in an area labeled “hazardous atmosphere.”  
**DO NOT** discard batteries in a fire.



### CAUTION

If your radio is programmed with volatile-key retention (consult your service technician), encryption keys will be retained for approximately 30 seconds after battery removal.

#### Note

The battery is shipped uncharged, and must be charged before use. Refer to the “Battery Charging and Disposal” section on page 72.

### Installing the Battery

1. Turn off the radio and hold it with the back of the radio facing upward.
2. Insert the top edge of the battery into the area at the top of the radio between the radio’s case and chassis. Make sure the three tabs on the radio chassis align with the three slots under the top edge of the battery.
3. Rotate the battery toward the radio, and squeeze the battery and radio together until the battery “clicks” in place.

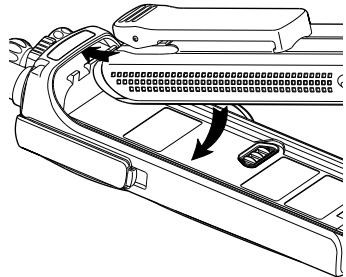

### Removing the Battery

1. Turn off the radio and hold it so that the release button on the bottom of the battery is facing upward.
2. Press downward on the release button so that the battery disengages from the radio.
3. Remove the battery completely away from the radio

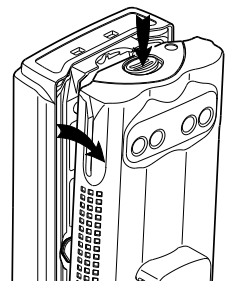

## Belt-Clip Installation and Removal

**Note**

The battery must be removed from the radio before the belt clip can be installed or removed.

### Installing the Belt Clip

1. Hold the battery in one hand so that the top of the battery faces upward, and the back of the battery faces you.
2. Holding the belt clip in the other hand with its top facing upward, align the slide assembly on the front of the belt clip with the slots on the back of the battery.
3. Slide the belt clip downward toward the bottom of the battery until the belt clip “clicks” in place.

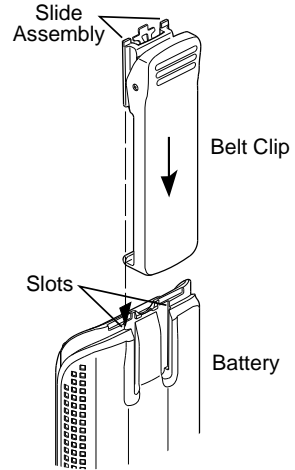

### Removing the Belt Clip

1. Hold the battery (with belt clip installed) in one hand so that the top of the battery faces upward, and the front (radio side) of the battery faces you.
2. At the top of the battery, press down on the belt clip’s metal tab and slide the belt clip upward until it disengages from the battery.
3. Continue to slide the belt clip upward until it is free from the battery.

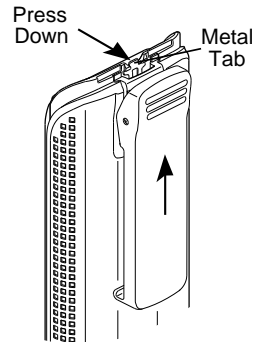

## Universal Connector Cover Installation and Removal

### CAUTION

When the universal connector is not in use, keep it covered with the universal connector cover.

### Installing the Universal Connector Cover

1. Looking at the antenna side of the radio, insert the top (flat) hooked end of the cover into the slot on the top of the radio, above the universal connector. Press downward on the cover's top to seat it in the slot.
2. While holding the cover seated in the top slot, insert the cover's bottom (rounded) hooked end into the slot below the universal connector. Press firmly inward on the cover's bottom until it snaps in place.

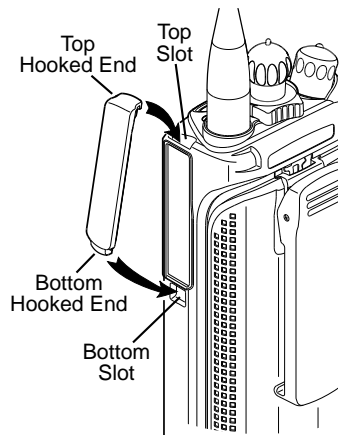

### Removing the Universal Connector Cover

1. Looking at the antenna side of the radio, insert a flat-bladed screwdriver into the area between the lower end of the universal connector cover and the slot below the universal connector.
2. Pry upward on the cover's lower end until it disengages from the radio.

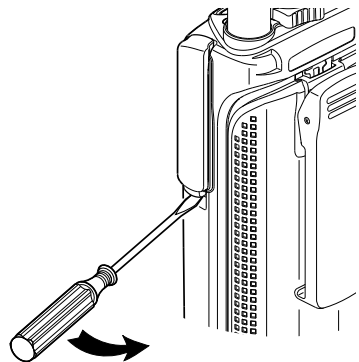





# 2

## General Radio Operation

After a fully-charged battery and an antenna have been connected to the radio, operation may begin. If necessary, refer to page 2 to insure a complete understanding of the radio's controls and indicators. Also, for your convenience, the "Additional Information" section (starting on page 67) contains a glossary, alert tone and status indicator tables, helpful tips, and an index.

### Turning the Radio On and Off

#### • Radio On

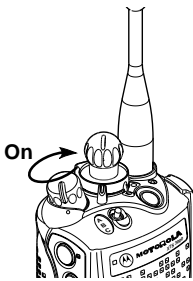

Turn the radio on by rotating the **On/Off/Volume Control Knob** *clockwise*. The radio then goes through a power-up self test, and the display shows "**Self Test.**"

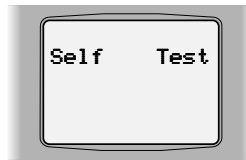

If the radio fails the self test, the display shows "**ERROR XX/YY,**" where **XX/YY** is an alphanumeric code. Turn the radio off, check the battery, and turn the radio back on. If the radio still does not pass its self test, record the "**ERROR XX/YY**" code and contact your nearest authorized service technician.

#### • Radio Off

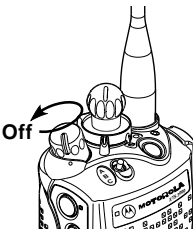

Turn the radio off by rotating the **On/Off/Volume Control Knob** *counterclockwise* until you hear a click.

## Selecting a Zone and Channel

A *zone* is a grouping of channels. A *channel* is a group of radio characteristics such as transmit/receive frequency pairs. After you turn your radio on, select the desired zone and channel.

- **Zone Selection**

- 1a. Press  until the **ZONE** softkey appears on the display. (The exact location of softkeys will vary based upon individual radio programming.)



OR

- 1b. Place the **Zone Switch** (if programmed, see page 2) to the desired position. Then go to step 5a or 5b.

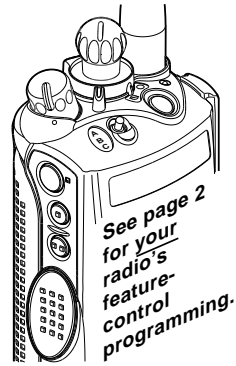

2. Press  directly below **ZONE**.



3. The display changes to show the current zone name (flashing) and the channel name (on steady). In the example shown, "POL" = Zone; "DISP NW" = Channel.

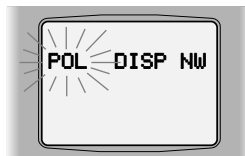

Zone = Flashing  
Channel = On Steady

- 4a. Press  until the desired zone name appears on the display.



- 4b. Enter the number of the desired zone.



OR

**Note**

If the selected zone is unprogrammed, the display will show “UNPROGRAMMED” until a valid programmed zone is selected. This does not mean your radio is unprogrammed; only the zone you selected is unprogrammed.

- 5a. To select the displayed zone/channel combination, press .

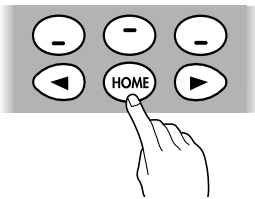

- 5b. To transmit on the displayed zone/channel combination, press the **PTT Switch**.

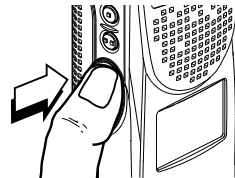

OR

**Note**

If you would like a different channel within the selected zone, see “Channel Selection” below.

• **Channel Selection**

(Consult your service technician to determine which one of the following methods to use for channel selection.)

**Method 1 Channel Selection** — used when the **16-Position Select Knob** is programmed for channel selection.

1. Once you have a desired zone displayed (step 4 of zone selection), *rotate* the **16-Position Select Knob** to the desired channel. The display changes to show the selected channel.

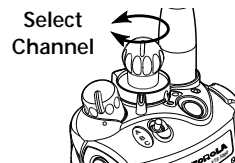

**Method 2 Channel Selection** — used when a softkey is programmed for channel selection.

1. Press  until the **CHAN** softkey appears on the display.



2. Press  directly below **CHAN**.



3. The display changes to show the zone name (on steady) and the current channel name (flashing). In the example shown, "**FIRE**" = Zone, "**DISP NW**" = Channel.

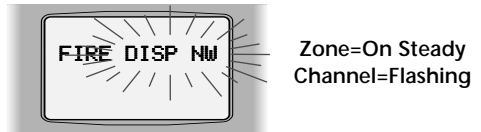

- 4a. Press  until the desired channel name appears on the display.



OR

- 4b. Enter the number of the desired channel.



**Note**

If the selected channel is unprogrammed, the display will show "UNPROGRAMMED" until a valid programmed channel is selected. This does not mean your radio is unprogrammed; only the channel you selected is unprogrammed.

- 5a. When the displayed zone/channel combination is acceptable, press .

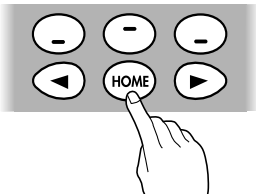

OR

- 5b. To transmit on the displayed zone/channel combination, press the **PTT Switch**.

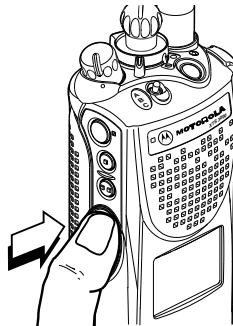

## Receiving/Transmitting

After you have turned your radio on and selected the desired zone and channel, you can receive (listen to) or transmit (send) communications as follows:

1a. Listen until you hear a transmission.

1b. Press the **Volume Set Button** (if programmed, see page 2) to hear the volume set tone.

1c. Press the **Monitor Button** (if programmed, see page 2) to listen for activity. See notes below.

OR

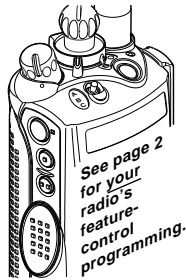

OR



2. Adjust the **Volume Control Knob** for a comfortable listening level.

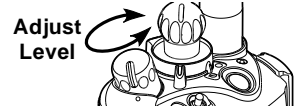

3. To transmit, press and hold the **PTT Switch** and speak clearly into the microphone. The LED will continuously light red while the radio is transmitting. When you have finished talking (transmitting), release the **PTT Switch** to listen (receive).

Transmit = Press & Hold PTT switch  
Receive = Release PTT Switch

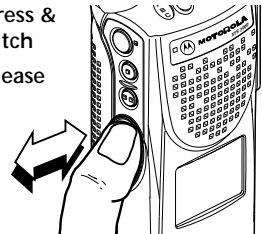

### Notes

- If the channel on which you are transmitting is programmed to receive Private-Line® (PL), ensure that the channel is not in use by momentarily pressing the **Monitor Button** (if programmed, see page 2) to listen for activity. To put the radio in permanent monitor operation (squelch defeat), press and hold the **Monitor Button** for five seconds (time programmable through radio service software). To return the radio to its original squelch state, tap the **Monitor Button** again or press the **PTT Switch**.
- If you try to transmit on a channel that is programmed for receive only, an invalid tone will sound until you release the **PTT Switch**.



## Using Lists

The “list” feature on your radio allows you to store commonly used numbers with an identifiable name. For example, the telephone feature has an associated list of names and telephone numbers.

The following general operations are available using lists:

- a preprogrammed list can be viewed
- a number in a list can be changed (reprogrammed)
- a specific member in a list can be selected



### • Viewing a List

1. Press  until the **VIEW** softkey appears on the display. (The exact location of softkeys will vary based upon individual radio programming.)





2. Press  directly below **VIEW**.

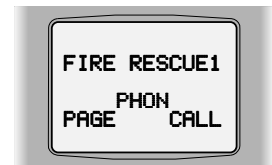

3. The display changes to show available lists (example: **PAGE, PHON, CALL**); use  or  to see other available lists.



- Press  directly below the list you wish to view. For example, to view the list of telephone numbers stored in your radio, press  directly below **PHON**.



- The display will show the first member in the list (name on the upper line, number on the lower line). The  status indicator will appear (on steady), indicating you are in the view mode.



 On Steady = View Mode  
(See page 71 for a description of all status indicators.)

## • Changing (Reprogramming) a List

### Notes

- Only numbers can be changed (reprogrammed) in a list. To change the names in a list, a qualified service center must reprogram your radio using radio service software. A name can be a maximum of 12 characters.
  - If you are using the scan feature, refer to page 48 for scan list reprogramming.
1. Press  until the **PROG** softkey appears on the display. (The exact location of softkeys will vary based upon individual radio programming.)







2. Press  directly below **PROG**.



3. The display changes to show the lists (**PAGE**, **PHON**, **CALL**, etc.) that can be changed.



4. Press  directly below the list you wish to change. For example, to change a telephone number, press  directly below **PHON**.



5. The display will show the first member in the list (name on the upper line, number on the lower line). The  status indicator will appear (flashing), indicating you are in the programming mode.



First Member in the List



Flashing = Programming Mode

To select a specific member from the list:

- 6a. Scroll through the list by pressing ◀ or ▶ until you locate the member's number you wish to change.

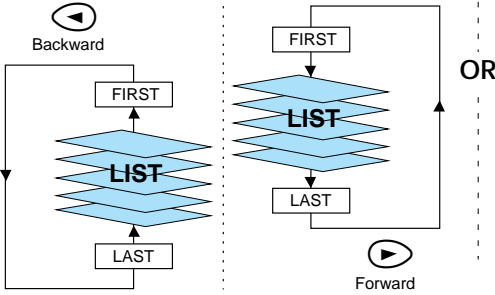

- 6b. Go directly to a specific member in the list by entering the number (1-19) that corresponds to that member's placement in the list.



7. When you stop on a member in the list, the display will show:



the member's name on the upper line;  
the number (telephone or ID) on the lower line.

8. Press the **Select Button** to enter the "programming— number-edit" mode.



9. You can now change numbers using any of the numeric keys (0 through 9wxy) and special function keys (\*, #).

The blinking cursor indicates the position of the next number to be added.







When the maximum number of digits has been entered, the cursor will disappear:

- 16 numbers maximum for a telephone number or  
8 numbers maximum for an ID number.

If you try to add any more digits, you will hear an invalid tone.

### Notes

- In the number-edit mode,  will function as a backspace key. Pressing this key will erase the previous digit, and the cursor will move to the left. When the last digit on the display has been erased, an additional press of , or pressing , will cause you to leave the number-edit mode without making any changes and re-enter the procedure at step 7.
- Some telephone systems may require a pause to be entered as part of the number dialed (for example, when dialing “9” to get an outside line). Pressing  followed by  will enter a pause in the number (shown as a “P” on the display).

10a. To save the change, press the **Select Button** again. This will also return you to the list (step 7) to make additional changes.

10b. To cancel the change, press . This will also return you to the home display and out of the change (reprogram) mode.

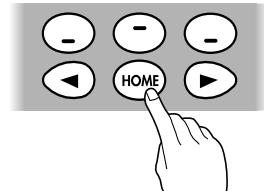
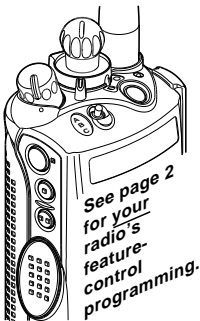

• **Selecting From a List**

- 1. Press  until the feature you desire appears as a softkey on the display.

For example, to select from the telephone list stored in your radio, press  until the **PHON** softkey appears on the display. (The exact location of softkeys will vary based upon individual radio programming.)



- 2. Press  directly below the desired feature.

Using the same example in step 1, press  directly below **PHON**.



- 3. The display changes to show the last telephone number dialed or the last ID number transmitted/received. The **LIST** softkey also appears.

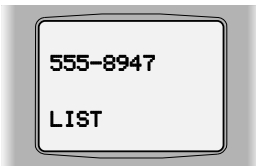

Last Telephone Number Dialed

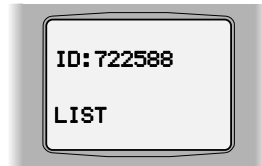

Last ID Number Transmitted/Received

- 4a. To access the preprogrammed list, press  directly below **LIST**. Then go to step 4b or 4c.



OR

- 4b. Scroll through the preprogrammed list by pressing ◀ or ▶ until you locate the desired member's name/number.

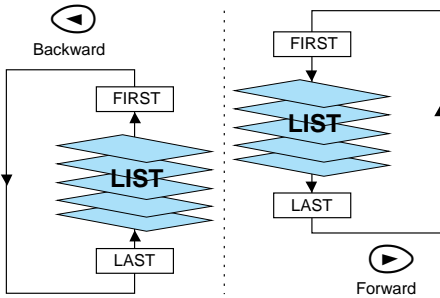

OR

- 4c. Go directly to a specific member in the list by entering the number (1-19) that corresponds to that member's placement in the list.



**Note**

If you are using the telephone feature (PHON), pressing the PTT Switch will transmit (send) the displayed number.

5. The display will alternate between the name and number (phone or ID) of a member in the list.

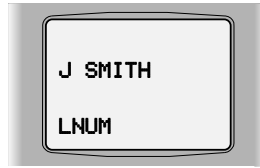
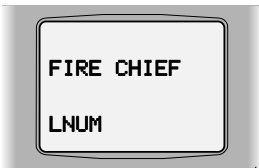

Note

- Pressing 0 twice, or - directly below the **LNUM** softkey, will take you to the Last telephone **NUM**ber dialed or the Last ID **NUM**ber transmitted/received.



- Once the **LNUM** softkey is displayed, you may go directly to any member in the list by entering the number (1-19) that corresponds directly to that member's placement within the list.



## General Radio Features

- **Radio Lock (Non-Secure Radios)**

The radio-lock feature enables you to select a unique numeric password. If the feature is enabled (programmable through the radio service software), you will see “**RADIO LOCKED**” on the display when the radio is turned on.



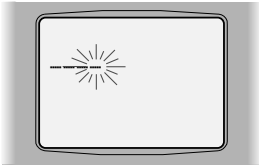

1. Enter your numeric password (1 to 8 characters).
2. As you enter the password digits, the radio will display dashes.



If a digit is mistakenly entered,  will function as a backspace key.

3. Once the correct password is entered, the radio will unlock.

### *To Change Your Password:*

1. Press  until the **PSWD** softkey appears on the display.
2. Press  directly below **PSWD**.
3. The display changes to show “**OLD PASSWORD.**”
4. Enter the correct old password.
5. If it is correct, the display will show “**NEW PASSWORD.**”
6. You then must enter the new password and press the **Select Button**.



### **Note**

In the event you forget the numeric password, you must have the radio's codeplug replaced by a qualified service technician and a new password programmed at that time through the radio service software.

- **Radio Lock (Secure Radios Only)**

By definition, this feature changes your radio to a more robust security system, which protects the use of the secure encryption keys. If this feature is enabled (programmable through the radio service software), you will see “**RADIO LOCKED**” on the display when the radio is turned on.



1. Enter your numeric password (8 characters maximum; minimum determined through radio service software).



2. As you enter the password digits, the radio will display dashes.

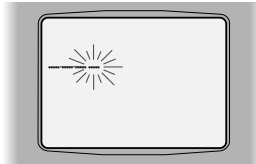

If a digit is mistakenly entered,  will function as a backspace key.

3. Once you have entered all the digits, press the **Select Button**.

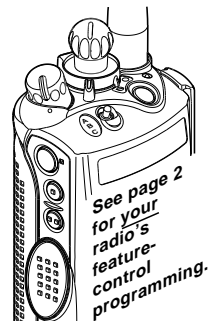



4a. If the password is correct, the radio will unlock.

4b. If the password is incorrect, the radio will remain locked. After you enter three incorrect passwords, the radio will display “DEAD LOCKED,” and

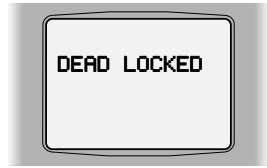

you must turn the radio off and then on in order to enter another password.

If you enter a total of 15 consecutive incorrect passwords (turning the radio off and on does not reset the number of incorrect tries), the radio will automatically erase all of its encryption keys and will display “RADIO LOCKED.”



**Note**





In the event you forget the numeric password, or enter in 15 or more incorrect passwords, enter in eight asterisks (“\*\*\*\*\*”) and press the **Select Button** (see page 2).



This action:

- unlocks your radio,
- erases all encryption keys, and
- the password will revert to the factory default password of “01234567”.

*To Change Your Password:*

1. Press  until the **PSWD** softkey appears on the display.
2. Press  directly below **PSWD**.
3. The display changes to show “**OLD PASSWORD.**”
4. Enter the correct old password and press  directly below **SEL**.
5. If it is correct, the display will show “**NEW PASSWORD.**”
6. Enter the new password and press  directly below **SEL**.

7. The display will then show **"CONFIRM."**
8. Re-enter the new password and press **(-)** directly below **SEL**.
- 9a. *If the two passwords match,* the radio will unlock.
- 9b. *If the two passwords don't match,* the display will show **"NEW PASSWORD."** You then need to repeat the previous steps.

### Note

You cannot change your password if you have entered three incorrect old passwords. The radio will exit the radio-lock feature and will not allow you to press the **PSWD** softkey-related button again until the radio is turned off and on again.

## • Radio-Lock Enable/Disable (Secure Radios Only)

This feature (programmable through radio service software) allows you to enable/disable the radio-lock feature using the radio's keypad.

*To Enable or Disable the Radio-Lock Feature:*

1. Press **(▶)** until the **LOGF** (for **"LOG OFF"**) softkey appears on the display.
2. Press **(-)** directly below **LOGF**.
3. The display changes to show the current selected state, **"PSSWD ENABLD"** or **"PSSWD DISBLD."**

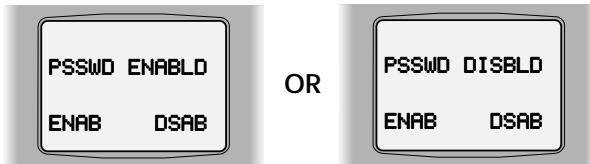

- 4a. To enable the radio-lock feature, press **(-)** directly below **ENAB**.
- 4b. To disable the radio-lock feature, press **(-)** directly below **DSAB**.

• **Muting the Keypad Tones**

The radio's keypad tones, normally heard each time a keypad key is pressed, can be turned off (muted) or on (unmuted) at your discretion.

*Muting Keypad Tones Using the Keypad-Mute Switch:*



**Note**

The **Keypad-Mute Switch** is programmable through radio service software.

To turn the keypad tones off, put the **Keypad-Mute Switch** in the “tones off” position.

To turn the keypad tones on for normal operation, put the **Keypad-Mute Switch** in the “tones on” position.

*Muting Keypad Tones Using the Softkey Feature:*

1. Press  until the **MUTE** softkey appears on the display.
2. Press  directly below **MUTE**.
3. The display changes to show the current mute state: “**TONES ON**” = tones unmuted; “**TONES OFF**” = tones muted.

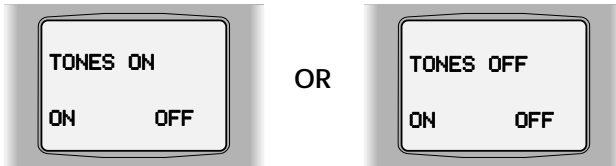
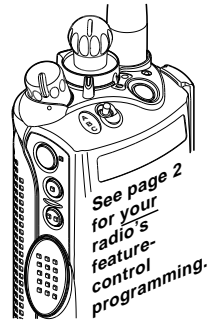

4. Press  below the desired mute state (**ON** or **OFF**).

**Note**

Pressing  or the **PTT Switch** will exit this display menu without changing the keypad tones muting selection.

### • Time-Out Timer

The new ASTRO portable radio is equipped with a programmable time-out timer which, upon expiration, will turn off the transmitter. This timer is programmable through radio service software and can be set from 0 seconds (off) to 7.75 minutes (465 seconds), at 15 second increments. The ASTRO radios have been programmed at shipment for 60 seconds.

1. A time-out timer warning occurs approximately four seconds before the allocated time-out timer expires. The warning is a short, low-pitched tone.
2. If the **PTT Switch** is held down longer than the time-out timer's allotted time, a continuous, low-pitched tone will sound and the LED will stop lighting red, indicating that your transmission has been cut off. This tone will continue to sound until the **PTT Switch** is released.
3. Release the **PTT Switch**.
4. To transmit another message, press the **PTT Switch**.

### • Low-Battery Indication

If the battery voltage falls below the low-voltage level, the  status indicator will appear (flashing).

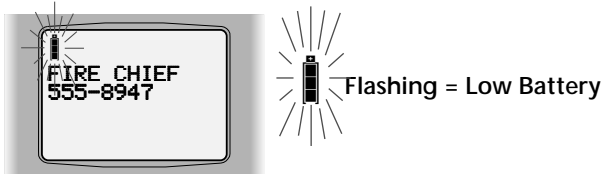

If a low-battery indication occurs, replace the battery.

Additional programmable battery status options:

- When the **PTT Switch** is pressed, the bicolor LED will blink red to indicate a low-battery condition.
- When the **PTT Switch** is released following a transmission, a short, high-pitched tone (chirp) will sound to indicate a low-battery condition.
- When the radio is in the standby mode and a low-battery condition occurs, an alert tone will sound from 30 to 930 seconds (programmable through radio service software) at 30 second increments.

# 3

## Common Radio Features

### Data Calls (Status Calls or Message Calls)

This feature allows you to send data calls (status calls or message calls) from your radio to the dispatcher to indicate a predefined condition. Each defined status or message can have a 12-character alias. You can have the following maximum number of predefined conditions: 16 message conditions; 16 status conditions for conventional; 8 status conditions for trunking.

- **Sending a Status Call or Message Call**

- 1a. Press  until the **STS** or **MSG** softkey appears on the display.



OR

- 1b. Press the **Status Button** or **Message Button** (if programmed, see page 2). This will take you directly to step 3.

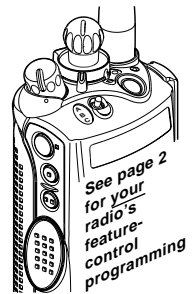

2. Press  directly below the type of data call you wish to make.



**STS** for Status Call  
**MSG** for Message Call



- The last acknowledged status call or the first message in the message list will be displayed.

**Note**

If no status has been acknowledged, the first status in the status list will be displayed.

- Scroll through the list by pressing  or  until you locate the predefined condition you wish to send.

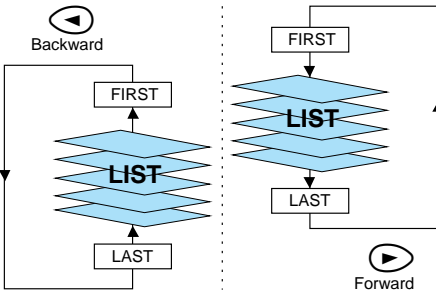

- Go directly to a specific predefined condition in the list by entering the number that corresponds to that condition's placement in the list.

OR



- When you locate the condition you want to send, press the **PTT Switch**.

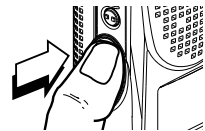

- Upon receipt of the data call, the dispatcher will transmit an acknowledge to your radio. Your radio will then beep four times, display **"ACKNOWLEDGE,"** and then return to normal dispatch operation.



If the system does not acknowledge the data call, your radio will alternately display **"NO ACKNOWLEDG"** and the currently selected predefined condition.



- Press  to exit the data-call feature and return to the home display.

**Notes**

- While the data-call feature is selected, you will not hear normal radio communications.
- If the data-call feature (**STS** or **MSG**) is selected and no activity occurs for six seconds, an alert tone will sound to indicate to you that the data-call feature is active. The alert tone will stop when  or the **PTT Switch** is pressed.

## Emergency

For radios programmed with the emergency feature, pressing the **Emergency Button** (if programmed, see page 2) will send out an emergency signal that takes precedence over any other signalling activity in progress on the selected channel. There are two types of emergency signals:

- **Emergency Alarm** sends a data transmission to alert the dispatcher to an emergency condition and identify the radio sending the emergency signal.
- **Emergency Call** is a type of dispatch operation which gives your radio priority access to channels (not available on conventional radios).

### Note

“Emergency” signals a critical situation. It should never be used for any other reason.

### • Entering the Emergency State

1. Press and hold the **Emergency Button** (if programmed, see page 2). The length of the press-and-hold time required is programmable through radio service software.

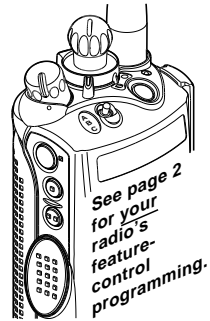

2. The display alternates between showing “**EMERGENCY**” and the current zone/ channel combination (except for silent-emergency alarm - see step 3b).



### 3a. Emergency Alarm

During a non-silent emergency alarm state:

- the LED will light,
- a short, medium-pitched tone will be heard,
- the display will show “EMERGENCY,”
- when the emergency alarm is acknowledged by the dispatcher, the radio sounds four beeps and the alarm ends.

OR

During a silent-emergency state:

- the LED will not light,
- tones will not be heard,
- the display will not change,
- the audio will be muted (turned off) and will remain so until you exit the emergency alarm state.

The silent-emergency state will continue until you press the **PTT Switch**.

OR

Press the **PTT Switch**.

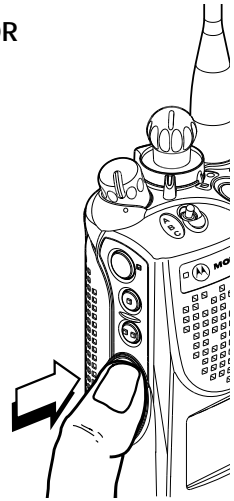

### Notes

- **For all types of emergency signals** — If you change channels while in emergency operation, the emergency alarm or call will be moved to, and continue on, the new channel if the new channel is also programmed for emergency operation. If the new channel is not programmed for emergency operation, an invalid-mode tone will sound until the emergency state is exited, or you change to a channel programmed for emergency operation.
- **For emergency-alarm with emergency-call signals** — After receiving the acknowledgment from the dispatcher, your radio will enter the emergency-call state.
- **For emergency-call signals** — While your radio is in emergency-call state, it operates in the usual dispatch manner. Or, if enabled in your radio, your radio will return to one of the following operations:
  - *Tactical/Non-Revert Operation* — you will talk on the channel you selected before entering the emergency state.
  - *Non-Tactical/Revert Operation* — you will talk on a preprogrammed emergency channel, and the emergency alarm will also be sent to this preprogrammed emergency channel.



- **Exiting the Emergency State**

It is important that you exit the emergency state when you have finished. There are four ways to exit the emergency state:

1. Press the **Emergency Button** for approximately 1 second (this time is programmable through radio service software); a medium-pitched, emergency-exit tone sounds until the button is released and the radio returns to normal operation.
2. Radios programmed with emergency alarm — the emergency alarm state may be exited by pressing the **PTT Switch**. The alarm will be canceled (without an emergency-exit tone), and you may begin transmitting your voice call.
3. On radios equipped with emergency alarm with call — pressing the **PTT Switch** while the radio is in emergency-alarm operation will place the radio in emergency-call operation.
4. Radios programmed with emergency alarm only — the emergency state is automatically exited upon reception of an acknowledgment from the dispatcher or if the alarms are exhausted when no acknowledgment is received. This method applies to non-silent emergency alarm radios.

**Note**

If you have a silent-emergency alarm radio, use method 1, 2, or 3 to exit the emergency alarm state.

- **Emergency Keep-Alive**

When this feature is enabled, moving the **On/Off Control Knob** to the off position will not turn your radio off if it is in an emergency state. Your radio will continue normal emergency operation as if the power is on. The radio will not turn power off until it exits the emergency state.

## Individual Calls

Individual calls are defined as follows:

- **Telephone Calls** — similar to standard telephone calls, except you use your radio. These calls can be landline caller to radio, radio to landline caller, or landline caller to radio talkgroup.
- **Private-Conversation™ II Calls (Private Calls)** — one-on-one calls involving two specific radios in which the conversation will not be heard by others in the current radio talkgroup.
- **Enhanced Private-Conversation Calls (Enhanced Private Calls)** — same as Private Conversation II calls except the radio automatically verifies that the target radio is active on the system. The target-radio user can also view the ID of the calling radio before answering.
- **Selective Calls (Conventional Channels Only)** — used to selectively call an individual or group of radios. It is intended to provide privacy and to eliminate the annoyance of you having to listen to conversations that are of no interest to you.
- **Call-Alert™ Pages** — your radio functions like a pager (beeper); Call Alert pages provide a means to signal other radio users that you wish to get in touch with them (even if they are away from their radio or in a noisy environment). Call Alert pages also allow you to verify that a radio is active on the system.

### Notes

In the following procedures, any reference to Private-Conversation (Private Call) will represent both Private-Conversation II calls and Enhanced Private-Conversation calls, unless otherwise specified.

• Selecting the Feature

**Note** On conventional channels, you must monitor the channel for activity before making an individual call (see page 16 for details).

1a. Press  until one of the following softkeys appear on the display:

**PHON** for a *Telephone Call*



**CALL** for a *Private-Conversation Call* or a *Selective Call*

**PAGE** for a *Call-Alert Page*

1b. If your radio has been programmed for “quick-access” to a feature (consult your service technician), press the designated button for either the **Phone**, **Private Call**, **Selective Call**, or **Call Alert** feature. This will take you directly to step 3.

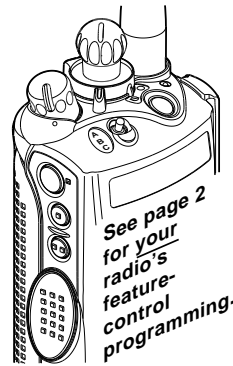
OR



2. Press  directly below the desired softkey feature. For example, to make a telephone call, press  directly below **PHON**.
3. The display changes to show the last telephone number dialed or the ID number of the last call/page transmitted/received.



Last Telephone Number Dialed

OR



Last ID Number Transmitted/Received

- Using the Feature

1. *Telephone Calls Only* — Your radio may be programmed to automatically access the telephone system (immediate access/auto access) or wait for you to do something (manual access/delayed access); consult your service technician to determine which way your radio was programmed.

- Immediate Access:

The display will show **“PLEASE WAIT”** while your radio attempts to access the telephone system.

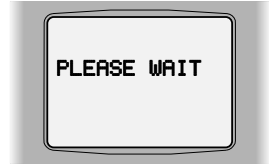

If the access was successful, you will hear a dial tone, and the display will again show the last number dialed.

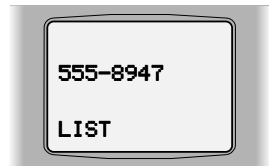

- Auto Access (Conventional Channels Only):

The display will show **“PLEASE WAIT”** while your radio attempts to access the telephone system via a radio-to-landline phone patch.



- Manual Access (Conventional Channels Only):

Enter a special telephone system access code using the keypad to access the telephone system via a radio-to-landline phone patch.



- Delayed Access:

Enter a new phone number or ID number using any of the numeric (0-9) keys; then press the **PTT Switch** (see following notes).

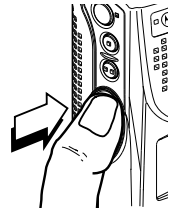

If the display shows “**NO PHONE**” or you do not hear a dial tone in any of the above situations, “hang up” (disconnect) by pressing **(HOME)** or the designated quick-access button (**Phone, Private Call, Selective Call, or Call Alert Button**).

If the display shows “**PHONE BUSY**,” your call is placed in queue until a line is available. When a line becomes available, the display changes to “**PLEASE WAIT**” and a dial tone is heard.

2. If the party you are calling answers, converse in the normal manner. Press the **PTT Switch** to talk; release the **PTT Switch** to listen.

Talk = Press & Hold PTT Switch  
 Listen = Release PTT Switch

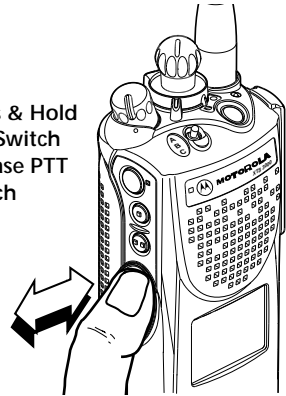

**Notes**

- After reaching the number you are calling, you may need to dial an extension number before you can reach your party.
  - Motorola trunked radios generate a high-pitched tone when the radio’s **PTT Switch** is released. This is heard by the landline party and is an indicator to begin talking.
3. When you have finished your conversation, or if the display shows “**NO PHONE**” or “**NO ACKNOWLEDG**,” “hang up” (disconnect) by pressing **(HOME)** or the **Phone Button**.

The radio will return to the home display.

- **Calling the Last Number Dialed or Last ID Number Transmitted/Received**

For *Telephone Calls Only* — Press the **PTT Switch**. You will either hear ringing or a busy tone. On a trunking system, if you hear a busy tone, press the **PTT Switch** to try again. Otherwise, press **(HOME)** to exit the Telephone Call feature.

For *Private-Conversation Calls Only* — Press the **PTT Switch**. Begin talking.

For *Enhanced Private-Conversation Calls Only* — Press the **PTT Switch**. If the radio you are calling is in service, you will hear ringing and, if the target-radio user responds to the call, the individual's voice.

For *Selective Calls* — Press the **PTT Switch**. Begin talking.

For *Call-Alert Pages Only* — If the page was accepted, you will hear four beeps, and the radio will return to the home display. If the page was not accepted, no beeps will be heard; press the **PTT Switch** to try again or press **(HOME)** to exit the Call-Alert Page feature.

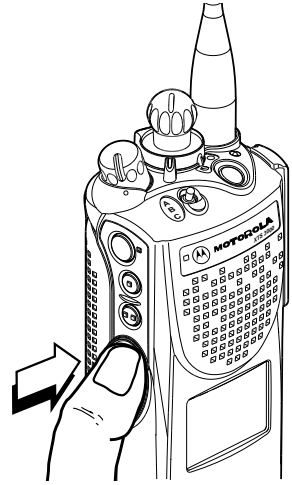

- **Calling a Number From a List**

Use the “list” feature to select a specific number from your radio’s memory list:

1a. Scroll through the list by pressing **(◀)** or **(▶)** until you locate the member’s number you wish to call.

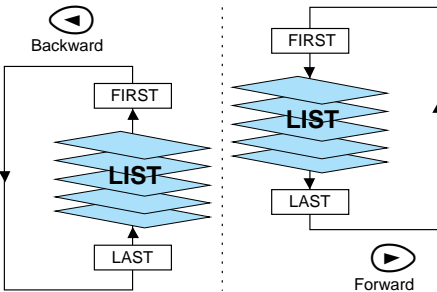

1b. Go directly to a specific member in the list by entering the number (1 through 19) that corresponds to that member’s placement within the list; then press the **PTT Switch**.

OR

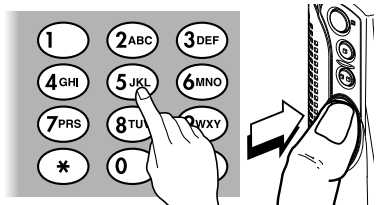

If the system does not acknowledge the call, your radio will alternately display “NO ACKNOWLEDG” and the currently selected number.

## • Calling a New Number

(if enabled through radio service software)

Enter a new phone number or ID number using any of the numeric (0–9) keys; then press the **PTT Switch** (see following note).

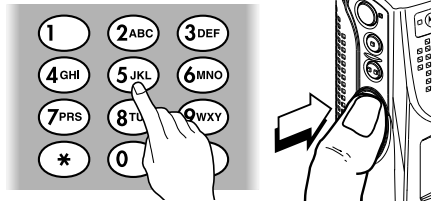

This action does not “program” a new number in your radio’s memory list; this is a temporary number only.

The first digit of the new number will be shown, and a blinking cursor, indicating the position of the next number to be added, is also displayed.

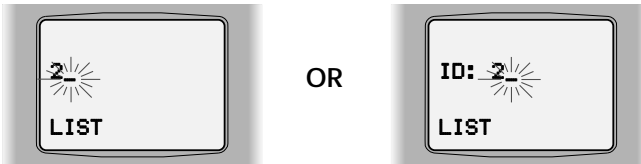

When the maximum number of digits (16 for a telephone number, 6 for a trunking ID number, and 4 for a conventional MDC ID number) has been entered, the cursor will disappear. If you try to add any more digits, you will hear an invalid tone.

### Note

Telephone Calls—Your radio may be programmed with either live dial or buffered dial; consult your service technician to determine which way your radio was programmed.

- **Live Dial:**  
Live dial will send out each digit as the key is pressed, in a similar fashion to a regular desktop telephone.
- **Buffered Dial:**  
Buffered dial will require that you enter all digits and then press the **PTT Switch**. Pressing **\*** followed by **#** will enter a pause in the number (shown as a “P” on the display). You may erase incorrectly entered digits by using **◀**, which acts as a backspace.

• Answering an Individual Call

1. When an individual call is being received, you will hear and/or see:
  - a telephone-type ringing if it is a telephone call;
  - two alert tones if it is a Private-Conversation call or selective call;
  - a continuous cycle of four tones if it is a Call-Alert page;
  - the LED blinking green;
  - the 🎵 indicator flashing; and
  - the display will show one of the following:

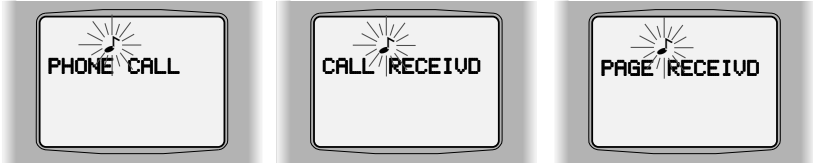

Telephone Call

Private-Conversation Call  
or Selective Call

Call-Alert Page

2a. **Telephone Calls Only** — Press the **Call Response Button**.



OR

2b. **Private-Conversation Calls and Call-Alert Pages with Private-Conversation** — Within 20 seconds, press the **Call Response Button**.

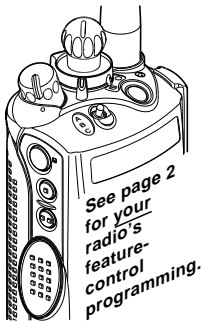

OR

2c. **Call-Alert Pages Only** — To see the caller's ID, press the **Select Button**.

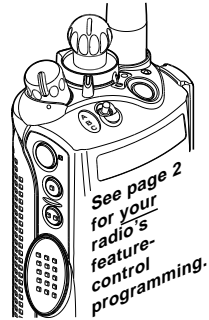

If you wish to respond, press the **PTT Switch** and your conversation will be heard by the entire talkgroup.

The display will show the caller's ID number. Press the **PTT Switch** to talk privately.  
**Selective Call** — The display will remain active for 2 seconds and then the speaker will unmute.



3. Converse in the normal manner. Press the **PTT Switch** to talk; release the **PTT Switch** to listen.

Talk = Press & Hold  
PTT Switch  
Listen = Release PTT  
Switch

4. When you have finished your conversation, “hang up” (disconnect) by pressing **HOME**. The radio will return to the home display.

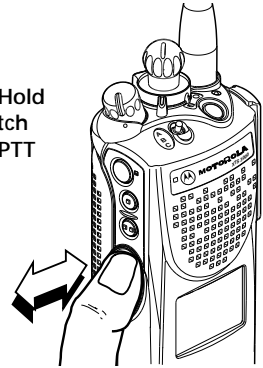

## PL Defeat

The PL defeat feature allows you to override any coded squelch (DPL, PL, or network ID) that may be programmed to a channel. To activate this feature, place the **PL Defeat Switch** (if programmed, see page 2) in the PL defeat position. You will then be able to hear any activity on the channel; if no activity is present, the radio is muted.

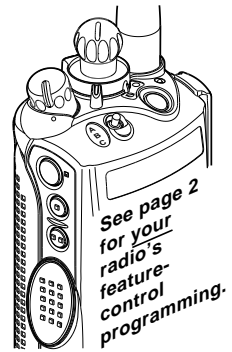

## Repeater Access

Repeater access allows you, the user, to selectively activate repeaters, which is especially useful in areas where repeaters are placed close together to ensure total coverage. Repeater access can operate automatically or manually and can be enable through radio service software on a per channel basis. During automatic repeater access, a sidetone is generated to indicate that the repeater access code is being transmitted to discourage you from talking over the data transmission.

In radios programmed with manual repeater access, you activate the repeater access code transmission by pressing the **Repeater Access Button** (if programmed, see page 2); no sidetone is generated. On radios with MDC-1200™ signalling, when the repeater access is acknowledged, the radio will emit an acknowledge alert tone. This acknowledge alert tone can be disabled through radio service software.

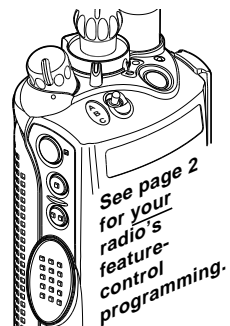

## Repeater/Direct

The repeater/direct feature allows you to bypass the repeater and talk directly to another radio. This is known as **DIRECT** operation or talkaround operation. The transmit frequency is the same as the receive frequency.

In **REPEATER** operation, you talk through the repeater, which increases the radio's operating range. The transmit frequency is not the same as the receive frequency.

### • Selecting Repeater or Direct Operation

- 1a. Press  until **DIR** appears on the display.



OR

- 1b. Place the Repeater/Direct Switch (if programmed, see page 2) in the "repeater" position or the "direct" position.

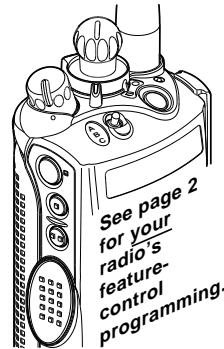

2. Press  directly below **DIR**.



3. The display will show the current operation for a few seconds and then the two possible operations.



OR



4. Press  below the desired operation (**DIR** or **RPTR**).

#### Notes

Pressing  or the **PTT Switch** will exit this display menu without changing the current operation

## Scan



Z = Scan Feature Active

The scan feature allows you to monitor activity on different channels by scanning a “scan list.” Each radio can have up to 20 different scan lists. The channels to be scanned can be programmed with the radio service software or manually by using the keypad.

Three types of scan lists are available (consult your service technician for additional information):

- **Trunking Priority Monitor** — Comprises channels that are all from the same trunking system (10 different channels maximum). This feature will work only on systems that support it.
- **Conventional** — Comprises only conventional channels (10 different channels maximum).
- **Talkgroup Scan** — Comprises conventional and trunked channels from more than one trunking system (10 different channels maximum). Priority operation is not available in this type of list.

There are also several types of scanning available:

- **Priority-One Scanning** — With priority-one scanning enabled, one member of the scan list is chosen as the priority-one member. Any activity on the priority-one channel will be heard on the speaker even if another channel in the scan list has activity on it.



- **Priority-Two and Non-Priority Scanning** — In addition to the priority-one channel being the number one priority, a second channel can be assigned as a priority-two channel, if desired. The remaining members in the scan list can be programmed as non-priority members of the scan list.



- **Automatic Scanning (Autoscan)** — With this feature, the radio begins scanning whenever you select a channel to which a scan list is assigned (strapped). The radio will continue auto scanning until you select a channel that does not have autoscan enabled.
- **Operator-Selectable Scan** — Scan can be programmed to be selected by a softkey related button or a **Scan On/Off Switch** (see page 2).

## • Turning Scan On and Off

- 1a. Press  until **SCAN** appears on the display.



OR

- 1b. Place the **Scan On/Off Switch** (if programmed, see page 2) in the “scan on” position or the “scan off” position.

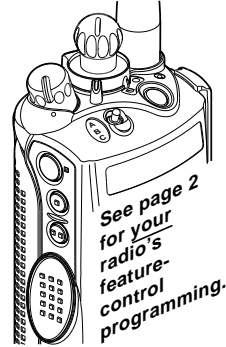



2. Press  directly below **SCAN**.

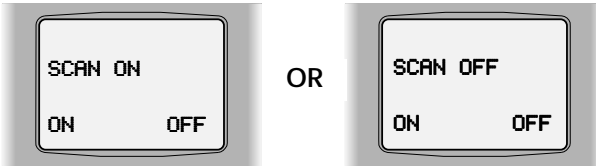

3. The display will show the current scan state.



4. Press  below the desired scan state (**ON** or **OFF**). When the scan feature is on (active), the scan indicator  is displayed.

### Notes

Pressing  or the **PTT Switch** will exit this display menu without changing the scan activity state.

## • Deleting Nuisance Channels

When the radio scans to a channel that you do not wish to hear (nuisance channel), you can temporarily delete the channel from the scan list.

1. When the radio is locked onto the channel to be deleted, press the **Nuisance-Delete Button** (if programmed, see page 2). Repeat this step to delete additional nuisance channels.

### Notes

Priority channels and the selected channel cannot be deleted using the nuisance-delete feature.

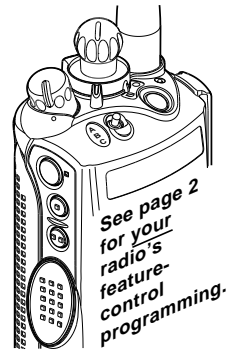

2. The radio continues scanning the remaining channels in the list. To resume scanning the deleted channel, you can change channels or leave and re-enter scan operation.
- ## • Dynamic Priority Change (Conventional Operation Only)

While the radio is scanning, the dynamic priority change feature lets you *temporarily* change any channel in a scan list (except the priority-one channel) to the priority-two channel. The present priority-two channel becomes a non-priority channel. This change remains in effect until scan is turned off, then scanning reverts back to the preprogrammed state.

1. When the radio is locked onto the channel to be designated as priority-two, press the **Dynamic Priority Button** (if programmed, see page 2).

### Notes

The priority-one channel cannot be changed to priority-two.

2. The radio continues scanning the remaining channels in the list. To resume scanning the preprogrammed priority-two channel, you must leave and re-enter scan operation.

## • Viewing a Scan List

The “view scan list” feature allows you to view the members of the scan list associated with the currently selected channel. You view a scan list the same way you view other lists (see “Viewing a List” on page 17).

• Programming a Scan List



**Notes** Priority channels and the selected channel cannot be deleted using the nuisance-delete feature.

1. Press  until the **PROG** softkey appears on the display.



2. Press  directly below **PROG**.



3. The display changes to show the lists (**PHON**, **CALL**, **SCAN**, etc.) that can be changed; use  or  to see other available lists.



4. Press  directly below **SCAN**.



5. The display will show the first member in the list. The  status indicator will appear (flashing), indicating you are in the programming mode.

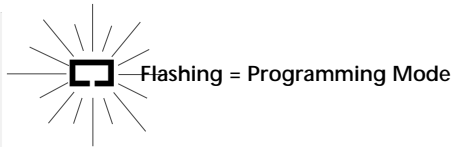

- 6a. Press  below the desired state (SEL or DEL).

**SEL** = add currently displayed channel to the scan list



**DEL** = delete currently displayed channel from the scan list

OR

- 6b. Press the **Select Button** (the **Top Side Button**) to change the scan-list status of the currently displayed channel.

**Notes**

Each press of the **SEL** softkey-related button, or the programmed **Select Button** (the **Top Side Button**), will cause one of the following to occur:

- The scan indicator () will appear to indicate that this channel has been added to the scan list.
- A “•” will be displayed next to the scan indicator () to indicate that this channel is the priority-two channel.
- The scan indicator will turn off to indicate that this channel has been removed from the scan list.

7a. Use ◀ or ▶ to select additional channels to be added or deleted from the scan list.

OR

7b. Use the keypad to go directly to a channel number to be added or deleted from the scan list.

OR

7c. Rotate the **16-Position Select Knob** to select additional channels to be added or deleted from the scan list.

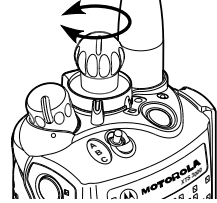

8. Press **HOME** to exit the scan list programming mode.

### Notes

The following notes are dependent upon your radio's programming; consult you service technician.

- A maximum of 16 channels can be added to the scan list (including the selected channel). If you try to add more than 16 channels to the scan list, the radio will sound an invalid tone to indicate the scan list is full.
- Anytime a new priority-one channel is assigned, the radio will automatically cancel the old priority-one channel assignment (radio service software programmable).
- Anytime a new priority-two channel is assigned, the radio will automatically cancel the old priority-two channel assignment (radio service software programmable).



## Selecting Squelch Operation

Tone Private-Line® (PL), Digital Private-Line™ (DPL), network ID, and carrier squelch operations are all available in the same radio on a per channel basis.

**Note**

Network ID is only available on ASTRO “digital” channels (consult your service technician).

When in carrier squelch operation, all traffic on the channel is heard. When in PL, DPL, or network ID operation, your radio responds to only those messages intended for you. PL, DPL, network ID, and carrier squelch can be programmed on a per channel basis.

Whenever the radio is operating in carrier squelch, the display will show the  status indicator.



 On Steady = Carrier-Squelch Operation

### Smart PTT

Smart PTT is a per-channel, programmable feature used in conventional radio systems to keep radio users from talking over other radio conversations. When smart PTT is enabled in your radio, you will not be able to transmit on an active channel. If you try to transmit (press the **PTT Switch**) on an active smart-PTT channel, an alert tone will be generated, and the transmission will be inhibited. The LED will also blink red to indicate that the channel is busy.

Three radio-wide variations of smart PTT are available:

- **Transmit Inhibit on Busy Channel with Carrier** — With this feature enabled, you will be prevented from transmitting if any activity is detected on the channel.
- **Transmit Inhibit on Busy Channel with Wrong Squelch Code** — With this feature enabled, you will be prevented from transmitting on an active channel with a squelch code or (if secure-equipped) encryption key other than your own. If the PL code is the same as yours, the transmission will not be prevented.
- **Quick-Key Override** — This feature can work in conjunction with either of the two above variations. With this feature enabled, you will be able to override the transmit-inhibit state by quick-keying the radio; in other words, two **PTT Switch** presses within the time programmed through radio service software (RSS) for **Smart PTT Quick-Key Timer** (default value is 1/2 second).

# Special Radio Features

## Dynamic Regrouping

The dynamic regrouping feature allows the dispatcher to temporarily reassign selected radios to a single special channel so that they can communicate with each other. This feature, enabled in each radio by means of the radio service software, is typically used during special operations. You will not notice whether your radio has this feature enabled until a dynamic regrouping command is sent by the dispatcher.

**Note**

If you select the dynamic-regrouping zone/channel using softkeys or other radio controls without being dynamically regrouped, an invalid tone will be heard.

1. When your radio has been dynamically regrouped, you will hear a “gurgle” tone (unless you are already on the dynamic-regrouping zone/channel), and your radio will be automatically switched to the dynamic-regrouping channel. The display will show the name assigned to the dynamic-regrouping channel.

**Note**

If you are using a radio control knob or switch (not softkeys) to select the zone or channel — Until you select the correct dynamic-regrouping position, you will not be able to select scan, telephone call, or Private Conversation call feature, and you will hear a gurgle tone each time you press the **PTT Switch**. This is a reminder to you that you are transmitting on the dynamic-regrouping channel, not the zone or channel indicated by the position of the radio control.

**Exception to this Note**

If your radio is programmed as a select-enabled radio: Once you select the correct dynamic-regrouping position, you can change the radio’s zone or channel knob/switch position, press the **PTT Switch**, which will transmit on the dynamic-regrouping zone/channel, and you will not hear the “gurgle” tone.

2. Talk and listen as usual.

3a. For Radios Using **Only Softkeys** for Zone **and** Channel Selection —

When the dynamic regrouping is cancelled by the dispatcher, the radio will automatically return to the original softkey zone and channel before the radio was dynamically regrouped.

3b. For Radios Using **Knobs or Switches** for Zone **and/or** Channel Selection—

When the dynamic regrouping is cancelled by the dispatcher, the radio will automatically return to the present knob/switch zone and/or channel position and the original softkey zone or channel selection.

OR

### • Reprogram Request

This feature allows you to notify the dispatcher that you want a new dynamic-regrouping assignment.

1a. Press  until the **RPGM** softkey appears on the display.

1b. Press the **Reprogram Request Button** (see page 2); then go to step 3.

OR

2. Press  directly below **RPGM**.

3. The display changes to show “**REPRGRM RQST**,” and the reprogram request is automatically sent to the dispatcher.



4a. If you hear one beep, press the PTT Switch to resend the reprogram request again, or press  to hang up and return to the home display.

4b. If you hear five beeps, the reprogram request was acknowledged by the dispatcher, and your radio will return to the home display.

**Note**

If the dispatcher fails to acknowledge the reprogram request within six seconds, a low-pitched alert tone sounds and the display changes to “**NO ACKNOWLEDG.**” Try again or press .

- **Select Enable/Disable**

The dispatcher may classify regrouped radios into either of two categories: select enabled or select disabled.

- Select-enabled radios are free to make channel changes to any available channel, including the dynamic-regrouping channel.
- Select-disabled radios cannot change channels since the dispatcher has specifically chosen to force the radio to remain on the dynamic-regrouping channel.

**Note**

The scan, telephone call, or Private Conversation call feature cannot be selected while your radio is select disabled.

## PTT-ID Receive

The PTT-ID receive feature allows you to see the radio ID number of the radio you are currently receiving. This ID can be a maximum of eight characters and can be viewed by both the receiving radio and the dispatcher. On trunking radios, pressing ◀ or ▶ will replace the displayed ID with the softkey menu selections; pressing (HOME) will bring back the ID display.

## PTT-ID Transmit

The PTT-ID transmit feature is a per channel feature where your radio's ID number is automatically sent every time the **PTT Switch** is pressed. Depending upon how your radio was programmed, your radio's ID can be transmitted at the beginning of a transmission, at the end of a transmission, or at the beginning and ending of a transmission. For digital voice transmissions, your radio's ID is sent during the voice message.

If your radio has MDC-1200™ signalling and the ID is sent before the voice transmission, you will hear a tone until the ID transmission is completed; this helps you avoid talking while the ID code is being transmitted.

*To view your radio's ID number:*

- 1a. Press ▶ until the **CALL** or **PAGE** softkey appears on the display.
2. Press ◯ directly below **CALL** or **PAGE**.
3. Press ◀.
4. The display changes to show your radio's ID.

- 1b. Press the **Call Button** or **Page Button** (if programmed, see page 2). Then go to step 3.

OR

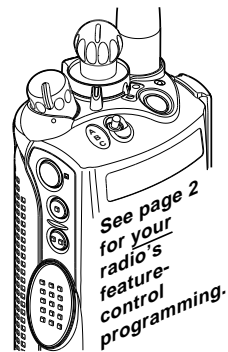
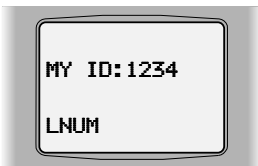

## Secure Operation

### Note

Secure operation provides the highest level of commercially available voice security on trunked or conventional channels. Unlike other forms of security, Motorola digital encryption provides signalling that makes it virtually impossible for others to decode any part of an encrypted message.

- **Selecting Secure or Clear Transmissions**

The **Secure/Clear Switch** (if programmed, see page 2) will set the transmit operation of the radio before the **PTT Switch** is pressed; the transmit operation cannot be changed while the **PTT Switch** is pressed.

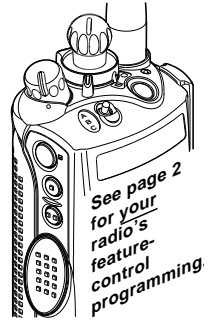

*If a channel is programmed for secure-only operation, and the **Secure/Clear Switch** is in the clear (○) position, when the **PTT Switch** is pressed, the display will show “SECR TX ONLY,” an invalid-mode tone will sound, and the radio will not transmit until the **Secure/Clear Switch** is set to the secure (Ⓢ) position.*



*If a channel is programmed for clear-only operation, and the **Secure/Clear Switch** is in the secure (Ⓢ) position, when the **PTT Switch** is pressed, the display will show “CLR TX ONLY,” an invalid-mode tone will sound, and the radio will not transmit until the **Secure/Clear Switch** is set to the clear (○) position.*



## • Managing Encryption



### KEY Loading

1. Refer to the key-variable loader (KVL) manual for equipment connections and setup.
2. When the KVL is attached to your radio, the display will show “**KEYLOADING**,” and all other radio functions will be locked out.



3. Pressing the KVL’s **PTT Switch** will load the encryption keys into your radio. When the key has been loaded successfully, the radio will sound a short tone for single-key radios; for multikey radios, an alternating tone will be heard.

### KEY Erasure (KEY Zeroization) — Method 1

1. Press  until the **ERAS** softkey appears on the display.
2. Press  directly below **ERAS**.
3. The display changes to show the last user-selected and stored encryption key and the available softkey selections.



**Note**



The scan, telephone call, or Private Conversation call feature cannot be selected while your radio is select disabled.

4. Press  directly below the desired softkey.

**ALL** = erases all the encryption keys in the radio. The display shows “**ERS ALL KEYS**” and **YES** and **NO** for erase confirmation.

**ABRT** = exits this menu and returns to the home display.

**SNGL** = selects the displayed encryption key to be erased. The display shows “**ERS SNGL KEY**” and **YES** and **NO** for erase confirmation.

Press  or  to scroll through the encryption keys or use the keypad to enter the encryption-key’s placement in the list. The display changes to show the new selection on the upper line.

5. Press , the **PTT Switch**, the **ABRT** softkey-related button, or turn the **16-Position Select Knob** to exit this menu.



*KEY Erasure (All KEYS Erased) — Method 2*

1. With the radio on, press and hold the **Top Side Button**; while holding this button down, press the **Emergency Button**.

**Note**

**DO NOT** press the **Emergency Button** before pressing the **Top Side Button** unless you are in an emergency situation; this would send an emergency alarm.

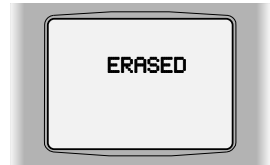

2. When all the encryption keys are erased, the display will show “ERASED.”

*MultiKEY*

The multikey feature allows your radio to be equipped with as many as 16 different encryption keys and supports up to two different encryption algorithms simultaneously (for example, DVP-XL™ and DES-XL, or DVP™ and DVP-XL).

- **Multikey** — The encryption keys can be tied (strapped), on a one-per-channel basis through radio service software. In addition, you can have operator-selectable keys, operator-selectable indices, and operator-selectable key erasure.
- **Trunked Multikey** — If you use your radio for both conventional and trunked applications, you will have to strap your encryption keys for trunking on a per-talkgroup or announcement-group basis. In addition, you may strap a different key to other features for example, dynamic regrouping, failsoft, emergency talkgroup, or emergency-announcement group.

*KEY Selection*

1. Press  until the **KEY** softkey appears on the display.
2. Press  directly below **KEY**.
3. The display changes to show the last user-selected and stored encryption key and the available softkey selections.



- 4a. Press ◀ or ▶ to scroll through the encryption keys.      OR      4b. Enter the number of the desired index.

**Note**

If an erased key is selected, the key name will be alternated with "ERASED KEY."

5. Press - directly below the desired softkey, or if you did step 4b, press ◀ or ▶ to scroll through the menu selections.

**PSET** or "**PRESET**" = selects the preset or default encryption key.

**SEL** = saves the newly-selected key and returns to the home display.

6. Press **HOME**, the **PTT Switch**, the **ABRT** softkey-related button, or turn the **16-Position Select Knob** to exit this menu. If the selected key is erased, "**KEY FAIL**" will be displayed and a momentary keyfail tone will be generated.



### Index Selection

The select-an-index feature allows you to select one or more groups of several encryption keys from among the available keys stored in the radio. For example, you could have a group of three keys structured to one index, and another group of three different keys structured to another index; by changing indices, you would automatically switch from one set of keys to the other. Every channel to which one of the original keys was tied to will now have the equivalent new key instead. Indexing allows the key-management controller to remotely change the keys within the index, that is not currently being used, without disrupting operation of the radio.

1. Press ▶ until the **INDX** softkey appears on the display.
2. Press - directly below **INDX**.
3. The display changes to show the last user-selected and stored index and the available index softkey selections.



4a. Press  directly below the desired index.

OR

4b. Enter the number of the desired index.

5. To save the newly selected index, press  below **SEL**. The radio will then exit index selection and return to the home display.

**Note**



Pressing  or the **PTT Switch** or turning the **16-Position Select Knob** will exit this display menu without changing the index selection.

## Selectable Power-Level

This feature allows you to select the power level at which your radio will transmit messages.

**Note**

The radio will always turn on to the default setting as determined through radio service software.

- 1a. Press  until the **PWR** softkey appears on the display.
2. Press  directly below **PWR**.

OR

- 1b. Press the **TX Power-Level Switch** (if programmed, see page 2). This will take you directly to step 3.

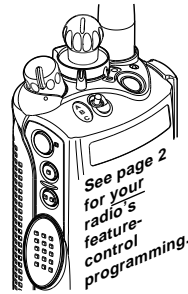

3. The display changes to show the current power-level state.

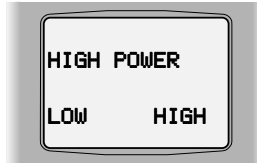

4. Press  directly below the desired power level. The new transmit power-level is saved, and your radio returns to the home display.

**LOW** = shorter transmitting distance; conserves battery life

**HIGH** = longer transmitting distance; lessens battery life

**Note**

Pressing  or the PTT Switch will exit this display menu without changing the power selection.

## Trunking System Controls

- **Busy Override**

When a talkgroup call is placed in a SmartZone™ system and the system is not able to obtain voice channels at all necessary sites, a busy tone will be generated. If so programmed in the zone manager and through the radio service software, you may override this busy by performing the following steps:

1. Press the **PTT Switch**; a busy indication is received.
2. Release the **PTT Switch**.
3. Press and hold the **PTT Switch** a second time. The busy tones are heard again. After a few seconds, a busy-override chirp will be generated (if so programmed), and the radio will send in a busy-override request.
4. The talkgroup call will be placed at all sites that have voice channel resources available. Other sites will be added to the call as channels become available. **Note:** Realize that not all members of the talkgroup will be able to hear a call when a busy override is requested.

- **Dispatcher-Interrupt**

The dispatcher-interrupt feature allows the dispatcher to interrupt your radio and place you in a Private Conversation call with the dispatcher.

1. When your radio receives a dispatcher-interrupt call, you will hear a repeating sequence of four, short, medium-pitched tones until you answer the call. The display will show “**DISP INTRUPT**” on the first line and “**PLEASE WAIT**” on the second line. The green LED will also flash to announce that a call is being received.

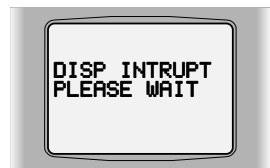

2. When the second line displays the ID of the dispatcher who has initiated the dispatcher-interrupt, press the PTT Switch and converse in the normal manner with the dispatcher.

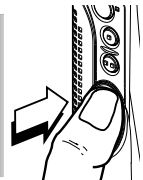

3. When you are finished with your conversation, hang up by pressing **HOME**. The radio will return to the home display.

- **Failsoft**

If a trunking system experiences a complete failure, the radio will revert to failsoft operation and automatically switch to its failsoft channel. During failsoft, the trunking repeaters will transmit a medium-pitched tone every 10 seconds. When the trunking system returns to normal operation, your radio will automatically leave the failsoft operation and return to trunked operation.



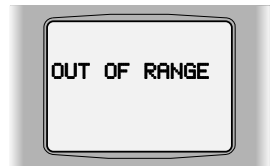

- **Out-of-Range**

If you go out of range of the system and can no longer lock onto a control channel, the display will alternately display “**OUT OF RANGE**” and the currently selected zone/channel combination, and/or sound a low-pitched tone. Your radio will remain in this out-of-range condition until it (1) locks onto a control channel, (2) locks onto a failsoft channel, or (3) the radio is turned off.



- **Site Lock**

This feature allows your radio to lock onto a specific site and not roam among wide-area talkgroup sites. This is particularly useful when operating at the fringe of a system's coverage.

- 1a. Press  until the **SITE** softkey appears on the display.
- OR
- 1b. Press the **Site Lock/Unlock Button** (if programmed, see page 2).
  - If the **Site Lock/Unlock Button** is a side button, the site-lock state will change, and the new state will be displayed momentarily.
  - If the **Site Lock/Unlock Button** is the top button, go to step 3.
2. Press  directly below **SITE**.
3. The display changes to show the current lock state.

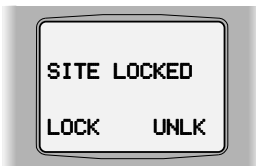

4. Press  directly below the desired condition (**LOCK** or **UNLK**). The new site-lock state is saved, and your radio returns to the home display.

- **Site Trunking**

If the zone dispatcher loses communication with any site, that site will revert to what is known as “site trunking.” Your radio will alternately display “**SITE TRUNKING**” and the currently selected zone/channel combination. When this occurs, you will only be able to communicate with other radios within your trunking site.



- **Site View and Change**

*Viewing the Current Site*

1. Momentarily press the **Site Search Button** (if programmed, see page 2).
2. The display will show the number of the current site, or if the radio is scanning for a new site, the display will show “**SCANNING SITE**” until it locks onto a new site, then it will show the number of the new site.

*Changing the Current Site*

1. Press and hold down the **Site Search Button** (if programmed, see page 2) to manually force the change to a new site.
2. You will hear a tone, and the display will show “**SCANNING SITE**” while the radio scans for a new site. Then, the radio automatically returns to the home display.









# 5

## Additional Information

### Glossary

<b>ACK</b>	Acknowledgement of communication
<b>Channel</b>	A group of characteristics such as transmit/receive frequency pairs, radio parameters, and encryption encoding
<b>Control Channel</b>	In a trunking system, one of the channels that is used to provide a continuous, two-way/data communications path between the central controller and all radios on the system
<b>Conventional</b>	Typically refers to radio-to-radio communications, sometimes through a repeater; does not use a trunking (controller) system (See Trunking)
<b>Cursor</b>	A visual tracking marker (a blinking line) that indicates a location on the display
<b>Dispatcher</b>	An individual who has radio system management duties
<b>FCC</b>	Federal Communications Commission
<b>Hang Up</b>	Disconnect
<b>Home Display</b>	The first display information after the radio completes its self test
<b>Landline Caller</b>	Someone communicating through the public telephone system
<b>LCD</b>	Liquid Crystal Display
<b>Page</b>	A one-way alert, with audio and/or display messages









<b>PTT</b>	Push-To-Talk - the PTT switch engages the transmitter and puts the radio in transmit (send) operation when pressed
<b>Radio-To-Landline</b>	Communicating from a portable/mobile radio through the telephone system.
<b>Repeater</b>	A conventional radio feature, where you talk through a receive/transmit facility (repeater), that re-transmits received signals in order to improve communications range and coverage
<b>RF</b>	Radio Frequency
<b>Softkeys</b>	Features shown on the display with a key-like outline - selection of these features is controlled by the  and  buttons
<b>Squelch</b>	The muting of audio circuits when received signal levels fall below a pre-determined threshold
<b>Standby</b>	An operating condition whereby the radio's speaker is muted but still continues to receive data
<b>Talkgroup</b>	An organization of radio users who communicate with each other
<b>Trunking</b>	The automatic sharing of communications paths between a large number of users (See Conventional)
<b>Zone</b>	A grouping of channels

## Alert Tones

Sound	Tone Name	Occurs:
<b>Short, Low-Pitched Tone</b>	Invalid Key-Press	when the wrong key is pressed
	Radio Self-Test Fail	when the radio fails its power-up self test
	No ACK Received	when the radio fails to receive an acknowledgement from the dispatcher
	Reject	when an unauthorized request is made
	Time-Out Timer Warning	four seconds before time out
<b>Continuous, Low-Pitched Tone</b>	Time-Out Timer Timed Out	after time out
	Talk Prohibit/ PTT Inhibit	when the PTT switch is pressed and transmissions are not allowed
	Out-of-Range	when the PTT switch is pressed and the radio is out of range of the system
	Invalid Mode	when the radio is on an unprogrammed channel
	Individual Call Warning Tone	when the radio is in an individual call for greater than 6 seconds without any activity
<b>A Group of Low-Pitched Tones (Busy Tone)</b>	Busy	when interconnect channel, phone line, or system is busy
<b>Short, Medium-Pitched Tone</b>	Valid Key-Press	when the correct key is pressed
	Radio Self-Test Pass	when radio passes its power-up self test
	Clear Voice	at the beginning of a non-coded communication
	Priority Channel Received	upon reception of activity on a priority channel
	Emergency Alarm Entry	upon entering the emergency state
	Central Echo	when the central controller has received a request from a radio

Sound	Tone Name	Occurs:
<b>Continuous, Medium-Pitched Tone</b>	Volume Set	when volume changed on a quiet channel
	Emergency Exit	upon exiting the emergency state
	PTT Sidetone	when data is sent by pressing the PTT switch, but the user must wait to talk
<b>A Group of Medium-Pitched Tones</b>	Failsoft	when system fails
	Automatic Call Back	when voice channel is available from previous request
	Talk Permit	upon pressing the PTT switch; verifying system accepting transmissions
	Dispatcher-Interrupter	Upon receipt of a dispatcher-interrupt call
	Keyfail	when an encryption key has been lost
	Console Acknowledge	when a status, message, emergency alarm, or reprogram request ACK is received
	Received Individual Call	when a Call Alert or Private Conversation call is received
	Call Alert Sent	when a Call Alert is received by the target radio
<b>Short, High-Pitched Tone (Chirp)</b>	Low-Battery Chirp	when battery is below preset threshold value
	Phone Dekey Chirp	from radio to phone line upon releasing the PTT switch
<b>Continuous, High-Pitched Tone</b>	Quik-Call™ Group Call	when a Quik-Call group call is received
<b>A Group of High-Pitched Tones</b>	Quik-Call Individual Call	when a Quik-Call individual call is received
<b>Ringling</b>	Phone Ringing	when a phone call is received
	Enhanced Call Received	when originator receives ACK from an enhanced private call
<b>Gurgle</b>	Dynamic Regrouping/Over-The-Air Programming	when a dynamic ID has been received and the PTT switch is pressed and the reprogrammed group has not been selected and when the radio is successfully re-keyed

## Status Indicators

Symbol	Indicator Name	Description
	Battery Status	flashes when the battery is low
	Carrier Squelch	indicates the radio is operating in the carrier-squelch mode
	Secure Operation	appears when your radio is in secure operation; on (Ⓢ) = secure; off (○) = clear-operation
	Call Received	flashes when an individual call is received
	Scan	indicates when the radio is in scan operation
	Priority-One Channel Scan	indicates when the radio is in priority-one channel scan operation
	Priority-Two Channel Scan	indicates when the radio is in priority-two channel scan operation
	View/ Programming	indicates when the radio is in the view or programming mode; on steady = view mode; flashing = programming mode
	Direct	indicates whether you are talking directly to another radio (talkaround) or through a repeater; on = direct; off = repeater

## Battery Charging and Disposal

- **Charging Batteries**

This product is powered by a nickel-cadmium (Ni-Cd) or nickel-metal-hydride (NiMH) rechargeable battery. Charge the battery before use to ensure optimum capacity and performance. The battery was designed specifically to be used with a Motorola charger. Charging in non-Motorola equipment may lead to battery damage and void the battery warranty.

**Note**

When charging a battery that is attached to the radio, turn the radio off to ensure a full charge.



**WARNING**

Do not attempt to change or charge the battery in a hazardous atmosphere.

The battery should be at about 77°F (room temperature) whenever possible. Charging a cold battery (below 50° F) may result in leakage of electrolyte and ultimately, in failure of the battery. Charging a hot battery (above 95°F) results in reduced discharge capacity, affecting the performance of the radio. Motorola rapid-rate battery chargers contain a temperature-sensing circuit to ensure that the battery is charged within these temperature limits.



**WARNING**

Care should be taken to avoid external short circuiting of the battery. A sustained high-rate discharge (for example, a paper clip placed accidentally across the battery contacts) may permanently damage the battery, void the battery warranty, and create a burn or fire hazard.

- **Recycling or Disposal of Batteries**



At the end of its useful life, the NiCd battery can be recycled. However, recycling facilities may not be available in all areas. Under various state or local laws, the battery must be recycled or disposed of properly and cannot be disposed of in landfills or incinerators.

For disposal, NiCd batteries should be delivered to an authorized metals reclamation dealer. NiMH batteries, although they contain no designated toxic metals, are recommended to be disposed of through an authorized metals-reclamation dealer.

In addition, U.S. Environmental Protection Agency (EPA) regulations classify used Ni-Cd batteries as hazardous waste, unless certain exemptions apply.

Motorola fully endorses and encourages the recycling of Ni-Cd batteries. If you are located in the United States or Canada, you can ship, post paid, your used Ni-Cd batteries to INMETCO, an EPA approved recycling facility, at the address listed below. If you are not located in the United States or Canada, you may ship your used Motorola Ni-Cd batteries to one of the nearest international locations listed below. Should you have any questions, contact the facility first.

Consideration should be given to the methods of collecting, labeling, and shipping used Ni-Cd batteries. Your federal, state or local EPA should be consulted for specific legal requirements and for recycling options in your area.

Motorola, as a responsible corporate citizen, has always been concerned with the protection of the environment. Please feel free to call the Motorola America's Parts Division, Customer Service Department, toll free, at 1-800-422-4210.

INMETCO, Bin #M1  
P.O. Box 720  
245 Portersville Road  
Ellwood City, PA 16117  
Phone: (412) 758-2800  
Fax: (412) 758-9311

HANIL METAL RECYCLE CO.,  
LTD  
24-4, Palryong-dong,  
Changwon-Shi  
Kyongsangnam-Do, Korea  
Phone: 082 551 93 1911  
Fax. 082 551 96 0050

S.N.A.M.  
Rue De La Gareene  
Z.I. Chesnes-Tharabie  
B.P. 733-38297 St. Quentin Fallavier Cedex  
France  
Phone: 033 74 94 59 85  
Fax. 033 74 94 13 18

NIPPON RECYCLE CTR. CORP.  
6-13-19, Nishitama, Kita-KuZ.I.  
Osaka, 530, Japan  
Phone: 081 6 311 9071  
Fax. 081 6 311 0949

For additional information on batteries, write to: Motorola • Energy Products Division • Customer Care Department • 1700 Belle Meade Court • Lawrenceville, GA 30243-5854.

## Helpful Tips

- If poor light conditions make the display, keypad, or channel numbers (around the **16-Position Select Knob**) difficult to read, turn on the radio's display, keypad, and channel backlights by pressing the **Light Button** (see page 2). These lights will remain on for a preprogrammed time before they turn off automatically, or you can turn them off immediately by pressing the **Light Button** again. If, while the lights are on, any key or button is pressed (except for the **Volume Knob** and the **PTT Switch**), any knob is turned, or any toggle switch is moved, the lights will remain on for an additional time period.
- Your radio's squelch level can be reprogrammed at an authorized service facility.
- If you suspect a radio problem, check the following items before requesting service:
  1. Radio Checks
    - Be sure the radio is turned on and the **16-Position Select Knob** is in the proper position.
    - Replace or recharge the battery. The first time a new battery is used, it should charge a minimum of 16 hours.
    - The antenna must be screwed on properly, with its base flush against the top of the radio.
    - Could your radio problem be caused by accessories improperly connected?
    - Try operating the radio from several different locations, especially when using the radio inside buildings.
    - Check the transmitter by transmitting to an alternate portable radio.
  2. Operating Instructions

Review your operating instructions and ensure that you are using the radio properly.
  3. Problem Not Solved

If, after following steps 1 and 2, your radio still has a problem, review your service agreement and call the applicable Motorola service representative. If you do not have a service agreement on your radio, contact your nearest authorized Motorola service shop for guidance toward a prompt and expedient evaluation and/or repair.



## Radio Care

- **Cleaning**

Clean external surfaces of your radio with the following solution: one teaspoon of mild dishwashing detergent to one gallon of water (0.5% solution).



### CAUTION

Do not use solvents to clean your radio; spirits may be harmful and permanently damage the radio housing.

Apply the detergent solution sparingly with a stiff, non-metallic, short-bristled brush, being careful not to allow excess detergent to remain entrapped near connectors and controls or in cracks and crevices. Do not submerge the radio in the detergent solution. Dry the radio thoroughly with a soft, lint-free cloth.

Clean all battery contacts with a lint-free cloth to remove dirt, grease, or other foreign material that may prevent good electrical connections.

- **Handling**

- Avoid physical abuse; do not pound, drop, or throw the radio unnecessarily. Do not carry the radio by the antenna.
- Avoid subjecting the radio to an excess of liquids. Never allow the radio to become submerged.
- Avoid subjecting the radio to corrosives, solvents, or spirits.
- Do not disassemble the radio in any way.
- Keep the accessory-connector cover in place until ready to use the accessory connector. Replace the cover immediately after the accessory has been disconnected.

## Air Bag Safety Information

### **WARNING**

An air bag inflates with great force. **DO NOT** place objects, including communications equipment, in the area over the air bag or in the air bag deployment area. If the communication equipment is improperly installed and the air bag inflates, this could cause serious injury.

- Installation of vehicle communication equipment should be performed by a professional installer/technician qualified in the requirements for such installations. An air bag's size, shape, and deployment area can vary by vehicle make, model, and front compartment configuration (for example, bench seat vs. bucket seats).
- Contact the vehicle manufacturer's corporate headquarters, if necessary, for specific air bag information for the vehicle make, model, and front compartment configuration involved in your communication equipment installation

## Service

Proper repair and maintenance procedures will assure efficient operation and long life for this product. A Motorola maintenance agreement will provide expert service to keep this and all other communication equipment in perfect operating condition. A nationwide service organization is provided by Motorola to support maintenance services. Through its maintenance and installation program, Motorola makes available the finest service to those desiring reliable, continuous communications on a contract basis. For a contract service agreement, please contact your nearest Motorola service or sales representative, or an authorized Motorola dealer.

Express Service Plus (ESP) is an optional extended service coverage plan, which provides for the repair of this product for a period of three years from the date of shipment from the factory, or the date of delivery if purchased from an authorized Motorola two-way radio dealer. For more information about ESP, contact the Motorola Radio Support Center at 3761 South Central Avenue, Rockford, IL 61102 (800) 227-6772 / (815) 874-1400.

## A

<b>ABRT</b> softkey . . . . .	58
Alert Tones . . . . .	69
<b>ALL</b> softkey . . . . .	58
Antenna . . . . .	4, 5
Arrow Keys . . . . .	4
Auto Access . . . . .	38

## B

Battery . . . . .	4, 30, 71-72
Belt-Clip . . . . .	8

## C

<b>CALL</b> softkey . . . . .	17, 19, 37, 48, 56
Call Alert Page . . . . .	36-43
<b>CHAN</b> softkey . . . . .	14
Channel . . . . .	12-15, 53, 67
Clear . . . . .	57
Computer Software Copyrights . . . . .	ii

## D

Data Calls . . . . .	31
<b>DEL</b> softkey . . . . .	49
Delayed Access . . . . .	38
<b>DIR</b> softkey . . . . .	44
<b>DSAB</b> softkey . . . . .	28
Dynamic Regrouping . . . . .	53, 70

## E

Emergency Alarm . . . . .	33-35, 59, 69
<b>ENAB</b> softkey . . . . .	28
Enhanced Private Conversation Call . . . . .	36-43
<b>ERAS</b> softkey . . . . .	58

## F

Failsoft . . . . .	64, 70
Factory Mutual Approval . . . . .	

H

**HIGH** softkey . . . . . 62  
Home Key . . . . . 4

I

ID. . . . . 37, 40-42, 51, 56, 70  
Immediate Access. . . . . 38  
Index . . . . . 77  
Indicators . . . . . 71  
Individual Call . . . . . 36-43, 70  
**INDX** softkey . . . . . 60

K

**KEY** softkey . . . . . 59

L

Light . . . . . 74  
List. . . . . 17-23, 48-50  
**LIST** softkey . . . . . 22, 22  
**LNUM** softkey . . . . . 23, 24  
**LOCK** softkey . . . . . 64  
**LOGF** softkey . . . . . 28  
**LOW** softkey . . . . . 62

M

Manual Access. . . . . 38  
Message . . . . . 31, 32  
Monitor. . . . . 16  
**MSG** softkey . . . . . 31, 32  
Multikey . . . . . 59  
**MUTE** softkey . . . . . 29

N

**NO** softkey . . . . . 58

O

**ON** softkey . . . . . 29, 46  
**OFF** softkey . . . . . 29, 46

## P

“P”	21
<b>PAGE</b> softkey	17, 18, 37, 56
Password	25-27
<b>PHON</b> softkey	17, 18, 22, 23, 37, 48
PL	16, 43, 51
Priority	17, 45, 47, 71
Private Call	36-43
Private Conversation Call	36-43
Private Line	16, 51
<b>PROG</b> softkey	18, 48
Program	18-21, 48-50, 71
<b>PSET</b> softkey	60
<b>PSWD</b> softkey	25, 27
<b>PWR</b> softkey	62

## R

Radio Lock	25, 26, 28
Receive	16
Reprogramming	17-21, 48-50, 54
<b>RPGM</b> softkey	54
<b>RPTR</b> softkey	44

## S

<b>SCAN</b> softkey	46, 48
Secure	25-28, 71
<b>SEL</b> softkey	27, 49, 60, 61
Selective Call	36-43
<b>SITE</b> softkey	64
<b>SNGL</b> softkey	58
Smart PTT	52
Softkeys	4, 68
Status	31, 71
<b>STS</b> softkey	31, 32

**T**

Talkaround ..... 44, 71  
Telephone Call ..... 36-42  
Time-Out Timer ..... 30, 69  
Transmit ..... 16  
TX Power-Level ..... 62

**U**

Universal Connector ..... 9  
UNLK softkey ..... 64

**V**

VIEW softkey ..... 17  
Volume Set ..... 16, 69

**Y**

YES softkey ..... 58

**Z**

Zeroization ..... 58  
Zone ..... 12-15, 53, 68  
ZONE softkey ..... 12



---

# Notes

---

---

---

---

---

---

---

---

---

---

---

---

---

---

---

---

---

---

---

---

---

---

---



# QUESTIONNAIRE

We believe that reports from users provide valuable information for producing quality operating instructions. Your comments and answers to the following questions will aid us in preparing manuals that contain accurate and complete information of maximum benefit to you.

In reference to Manual No. **68P81083C75-O**



1. Please check all the appropriate boxes:

		Clear	Confusing	Too Detailed	Too Brief	Adequate	Complete	Incomplete	Incorrect	Not Covered in This Manual
Controls and Features	text									
	illustrations									
Operating Procedures	text									
	illustrations									
Alert Tone Explanations										
Battery Information										
Options										
Model Information										
Accessories										
General Care Information										
Other (specify)										

- 2. For illustrating procedures, do you prefer:
  - photographs     line drawings     no preference
- 3. How would you rate the overall organization of this manual?
  - excellent     very good     good     fair     poor
- 4a. If this manual has a "quick reference card," do you use it?
  - yes     no
- 4b. If yes, how useful is it to you?
  - extremely     very     somewhat     not very
- 5. How do you rate this manual overall?
  - excellent     very good     good     fair     poor
- 6. Comments/Recommendations for improving operating instructions.

---



---



---

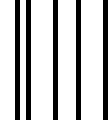

NO POSTAGE  
NECESSARY  
IF MAILED  
IN THE  
UNITED STATES

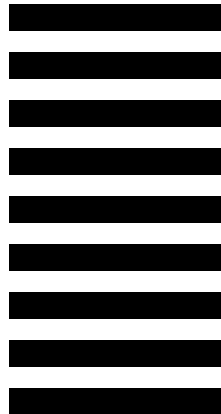

**BUSINESS REPLY MAIL**  
FIRST CLASS MAIL PERMIT NO 9040 FT. LAUDERDALE, FL

POSTAGE WILL BE PAID BY ADDRESSEE



**MOTOROLA**

Attention: Technical Communications  
8000 W. Sunrise Boulevard  
Ft. Lauderdale, FL 33322

